

2135408COM 2 Door 1 Drawer Base Cabinet

systembuild™
EVOLUTION

Date of Purchase ___ / ___ / ___
Lot Number:

B342135408COM0

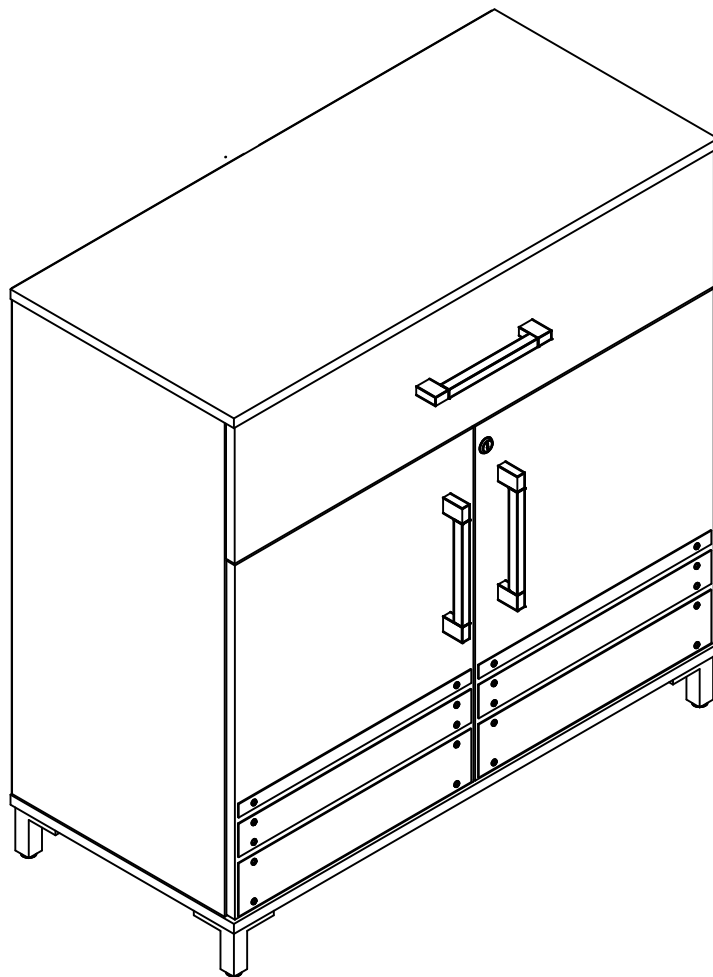

Do Not Return This Product!
Contact our customer service team for help first.
Call: 1-866-452-4081 (toll free)
Monday-Friday 9am - 5pm CST
Visit: www.systembuild.com

THIS INSTRUCTION BOOKLET CONTAINS **IMPORTANT** SAFETY INFORMATION. PLEASE READ AND KEEP FOR FUTURE REFERENCE.

Secure Your Furniture

Keep your home and family safe with the wall anchor kit that is included with the product.

Serious or fatal crushing injuries can occur from tipping furniture.

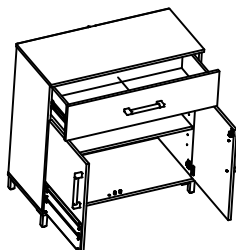

WARNING: Manufacturer assumes no liability for improper installation or excessive loads placed on screws or bracket. This wall anchor is not a substitute for proper adult supervision.

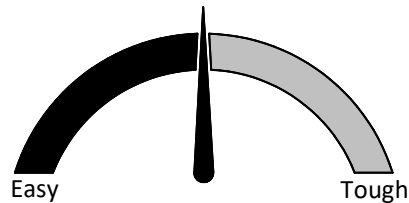

Assembly Difficulty Meter

Follow Ameriwood Home



Contact Us!

Do NOT return this product!

Contact our friendly customer service team first for help.

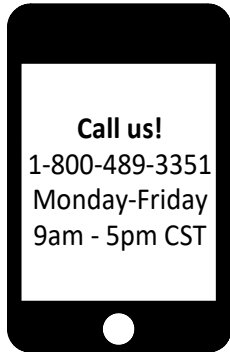

Visit ameriwoodhome.com to view the limited warranty valid in the U.S. and Canada.

Assembly Tips



Helpful Hints

PEOPLE NEEDED FOR ASSEMBLY: 1-2

- Open your item in the area you plan to keep it to avoid excessive heavy lifting.
- Identify, sort and count the parts before attempting assembly.
- Compression dowels are lightly tapped in with a hammer.
- Slides are labeled with a **R** (right) and **L** (left) for proper placement.
- Make sure to always face the point on the top of the Cam Lock towards the outer edge.
- Use all the nails provided for the back panel and spread them out equally.
- Back panel must be used to make sure your unit is sturdy.
- Do NOT use harsh chemicals or abrasive cleaners on this item.
- Never push, pull, or drag your furniture.

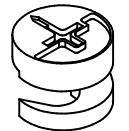

Before You Start

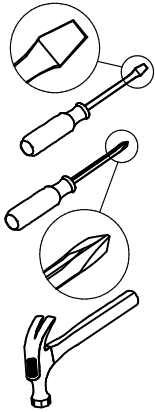
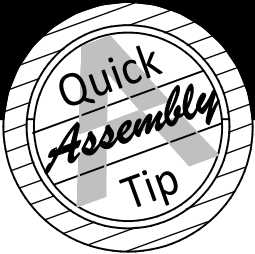

- ✓ Read through each step carefully and follow the proper order
- ✓ Separate and count all your parts and hardware
Parts are labeled on the surface or edge of the part
- ✓ Give yourself enough room for the assembly process
- ✓ Have the following tools: Flat Head Screwdriver, #2 Phillips Head Screwdriver and Hammer
- ✓ Caution: If using a power drill or power screwdriver for screwing, please be aware to slow down and stop when screw is tight. Failure to do so may result in stripping the screw.

Cam Lock Fastening System

This Cam Lock Fastening System will be used throughout the assembly process.

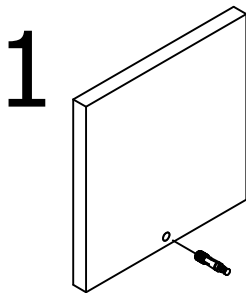

1 Press CAM BOLT into hole.

2

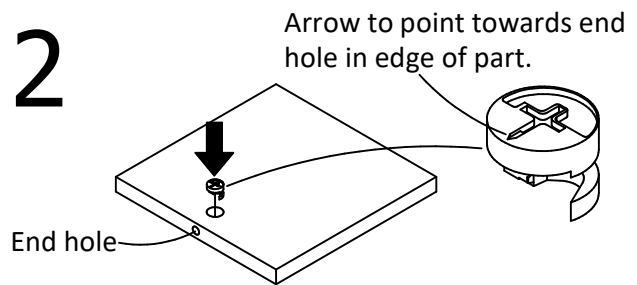

End hole

Press CAM LOCK into hole.

3

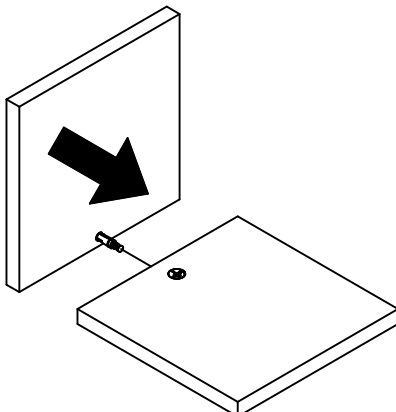

Press parts together so CAM BOLT inserts into edge hole.

4

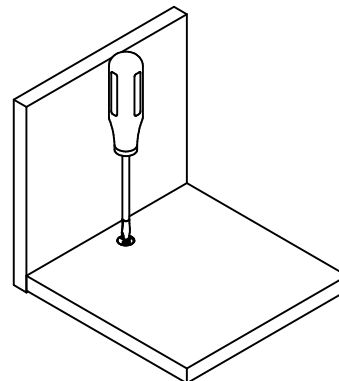

Using a screwdriver, turn the CAM LOCK clockwise to lock the CAM LOCK and CAM BOLT into their holes and fastening parts together.

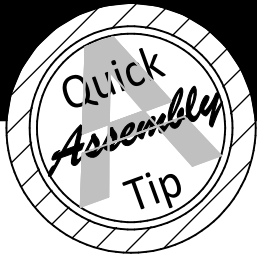

Before You Start

Please Note:

You may need to lightly tap the wood dowels into the holes during your assembly process.

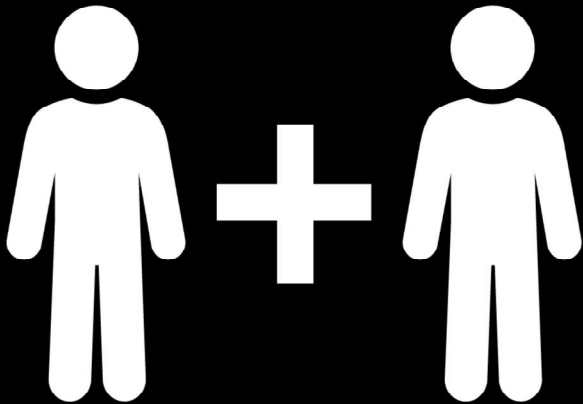
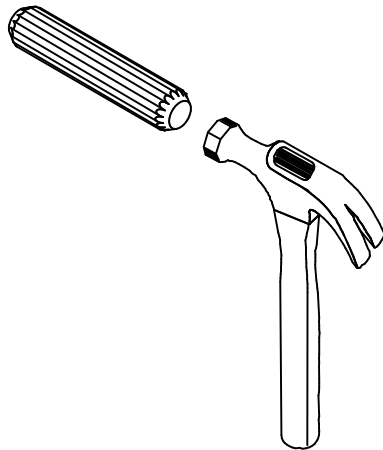

2 PEOPLE NEEDED FOR ASSEMBLY

**2 PERSONAS NECESITADAS
PARA LA ASAMBLEA**

**2 PERSONNES NÉCESSAIRES
POUR L'ASSEMBLAGE**

CAUTION: Failure to use 2 people for assembly could result in unit damage or personal injury.

PRECAUCIÓN: Si no se utilizan 2 personas para el ensamblaje, se pueden producir daños en la unidad o lesiones personales.

ATTENTION: Échec d'utiliser 2 personnes pour l'assemblage peut causer du dommage au meuble ou causer des blessures.

Board Identification

Not actual size

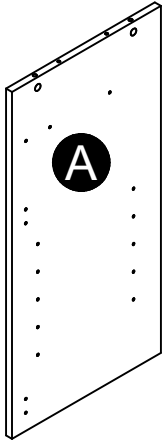

Left Panel
32135408010

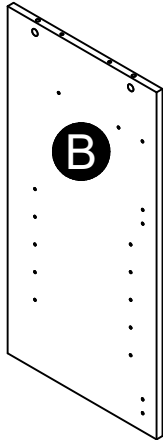

Right Panel
32135408020

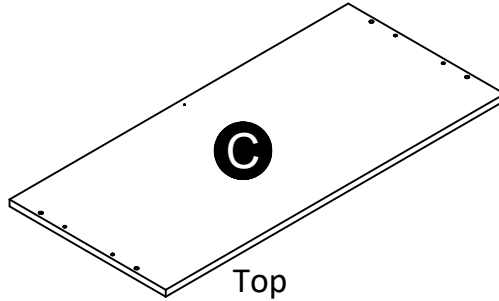

Top
32135408030

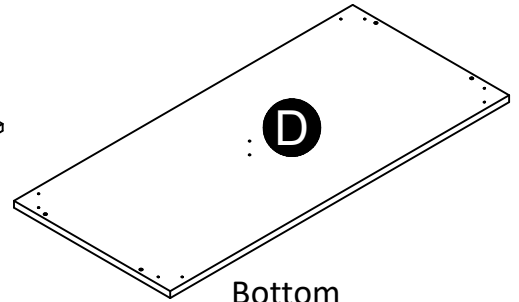

Bottom
32135408040

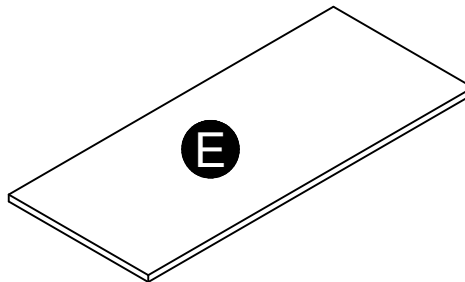

Adjustable Shelf
34888408050

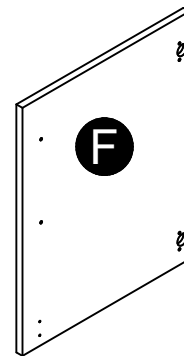

Left Door
32135408060

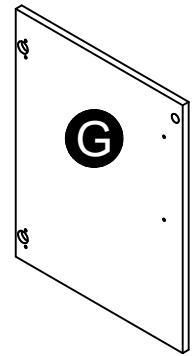

Right Door
32135408070

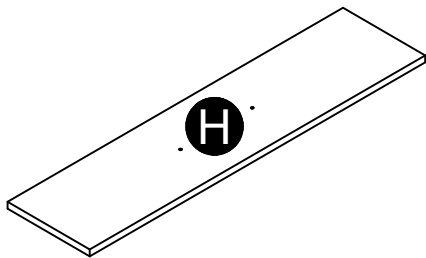

Drawer Front
32135408080

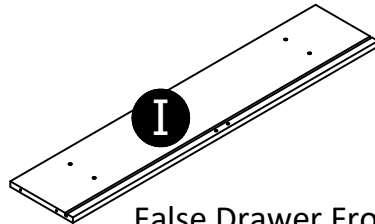

False Drawer Front
32135407090

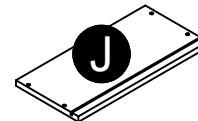

Left Drawer Side
32135407100

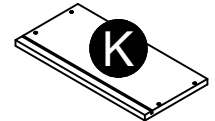

Right Drawer Side
32135407110

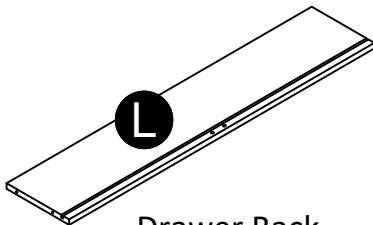

Drawer Back
32135407120

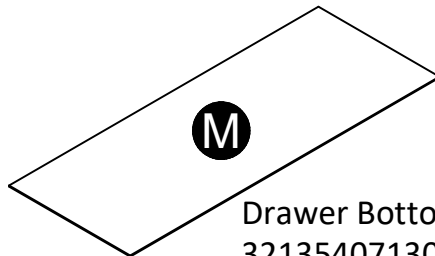

Drawer Bottom
32135407130

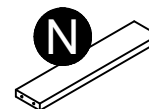

Drawer Brace
32135000140

Board Identification

Not actual size

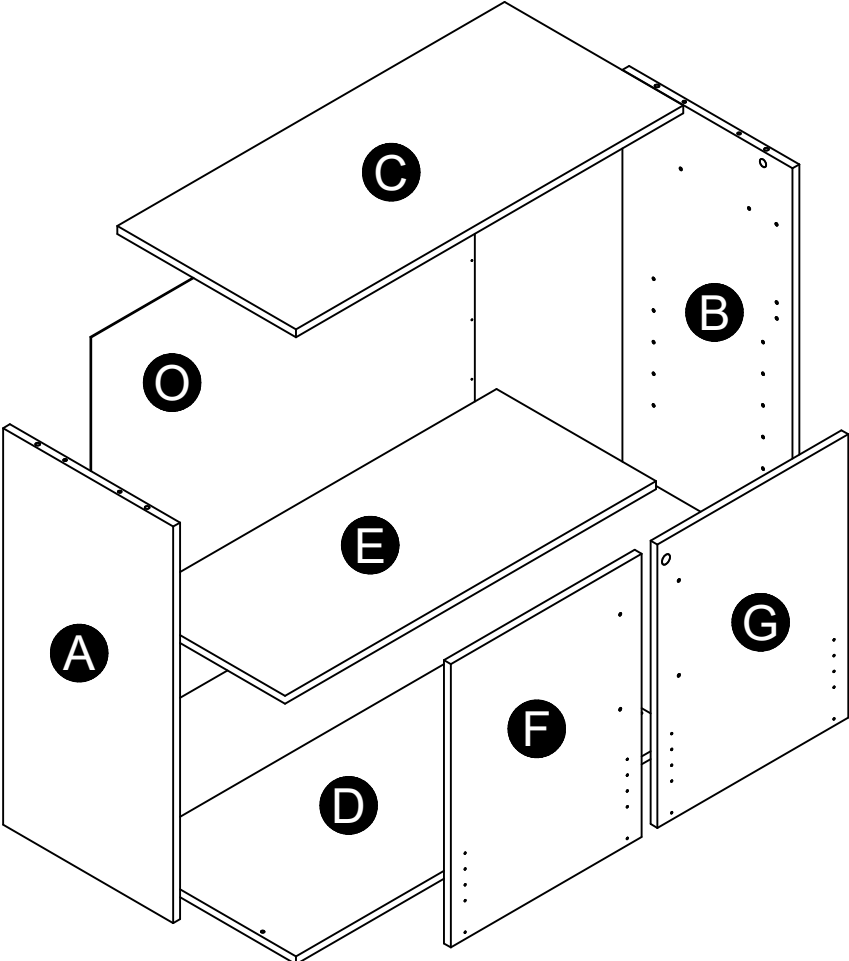

This part is made of paperboard construction. It is not made from wood, but is required for the assembly of your unit.

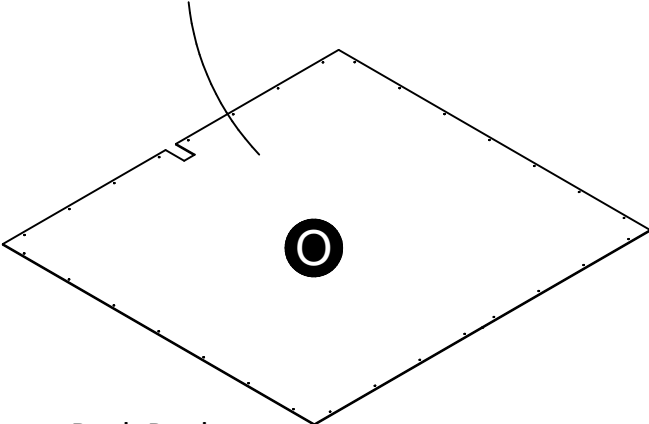

Back Panel
K488840800

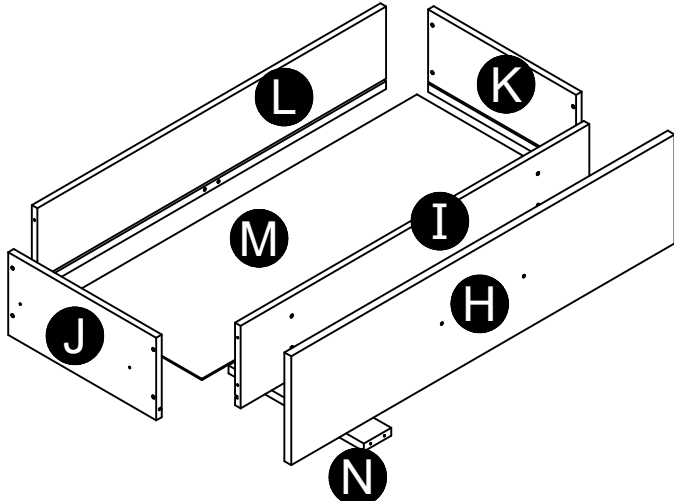

Part List

Actual Size

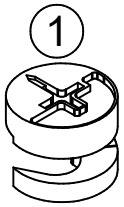

(x4)
#A22700
cam lock

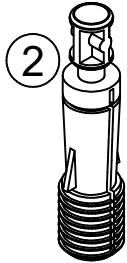

(x4)
#A22710
cam bolt



(x4)
#A21670
wood dowel

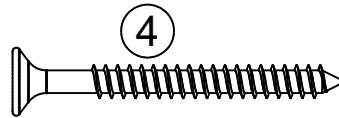

(x12)
#A13410
1-3/4" flat head screw



(x26)
#A12105
7/16" pan head screw



(x2)
#A11170
5/8" pan head screw

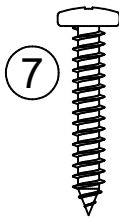

(x14)
#A12810
1" pan head screw

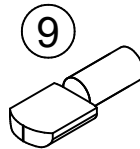

(x4)
#A80250
shelf support

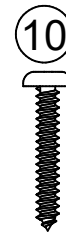

(x2)
#A11210
3/4" pan head screw



(x4)
#A17400
7/8" bolt



(x2)
#A17410
7/8" bolt



(x6)
#A11070
euro screw

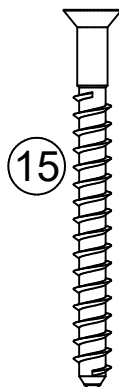

(x4)
#A23030
confirmat screw

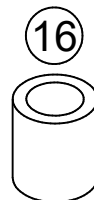

(x2)
#A89020
plastic stop

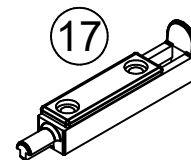

(x1)
#A55410
slide bolt

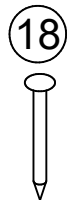

(x30)
#A21110
nail

Part List

Not Actual Size

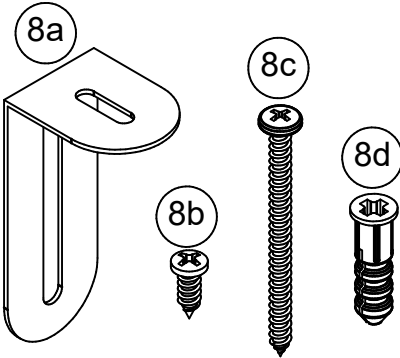

(x1)
8 #A84050
safety bracket

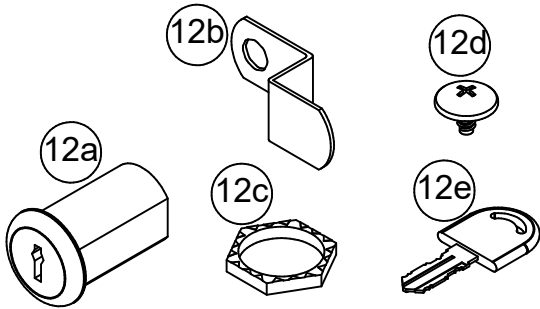

(x1)
12 #A55055
lock

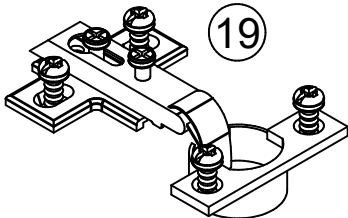

(x4)
19 #A65615
hinge

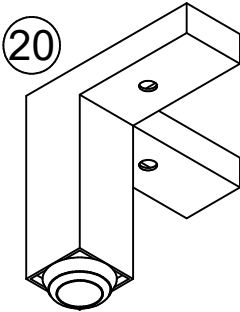

(x5)
20 #A44710
foot

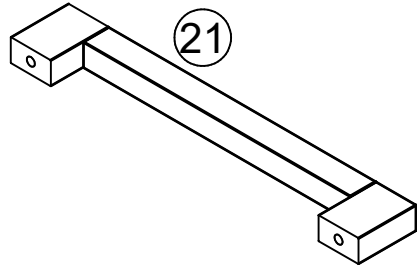

(x3)
21 #A55010
handle

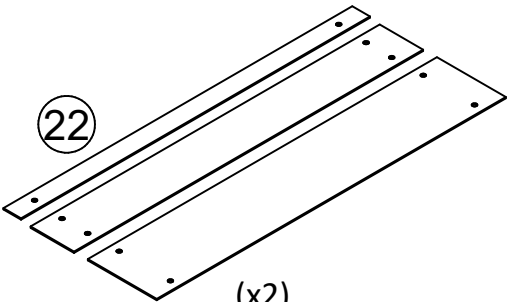

(x2)
22 #A92550
base plate kit

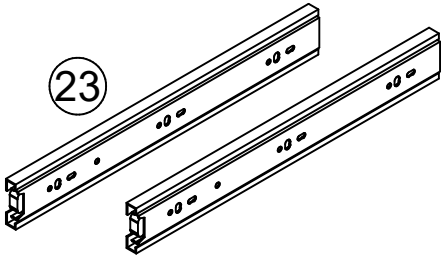

(x1)
23 #A56100
drawer slide

STEP 1

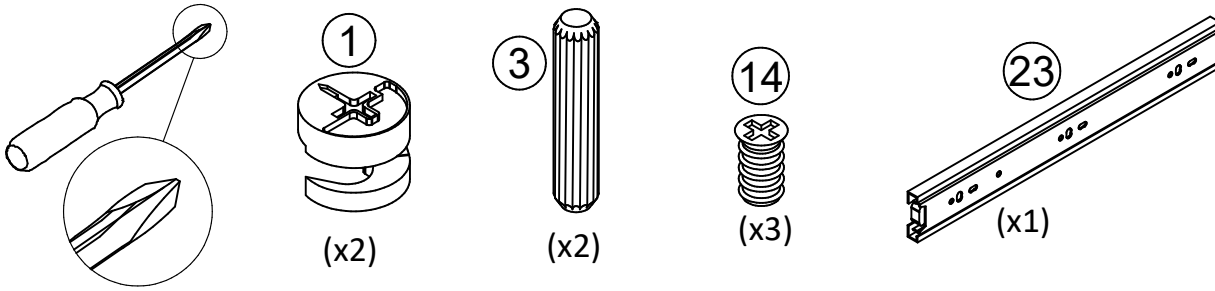

Locate the slide kit (21). Extend the slide as shown and press the release lever to remove the inner slide. Set the inner slide aside for later. Start by attaching the slide to the panels at the rear of the slide. While sliding the middle slide locate the holes in the panels with the access hole in the middle slide and fasten with screws (20) as shown.

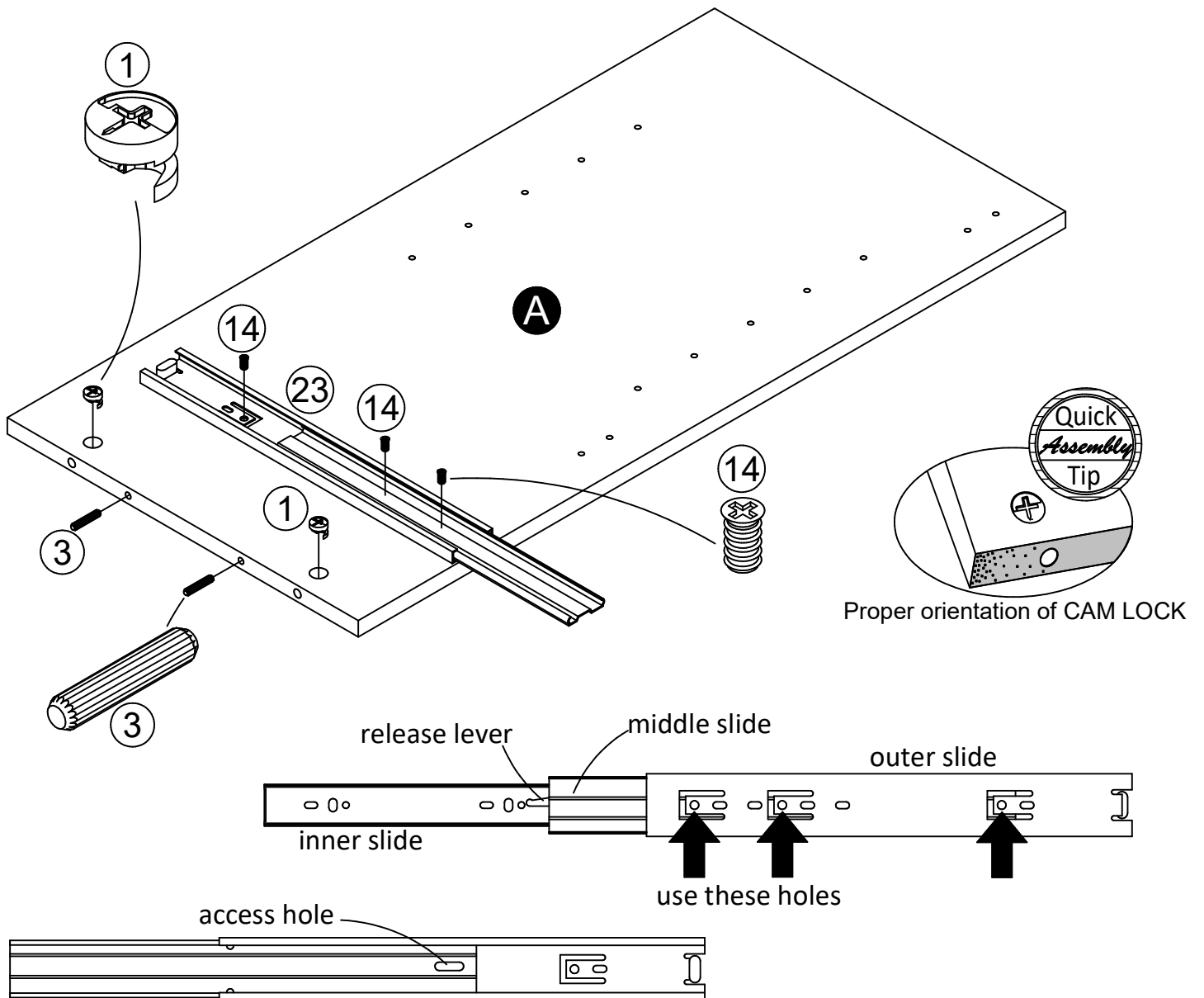

STEP 2

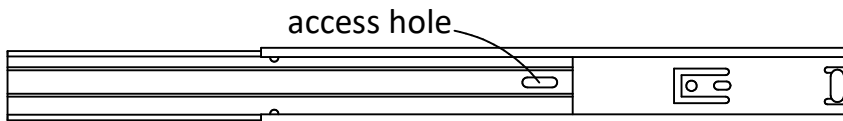
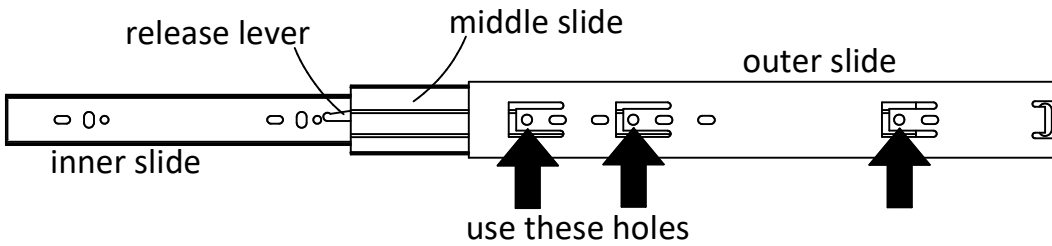
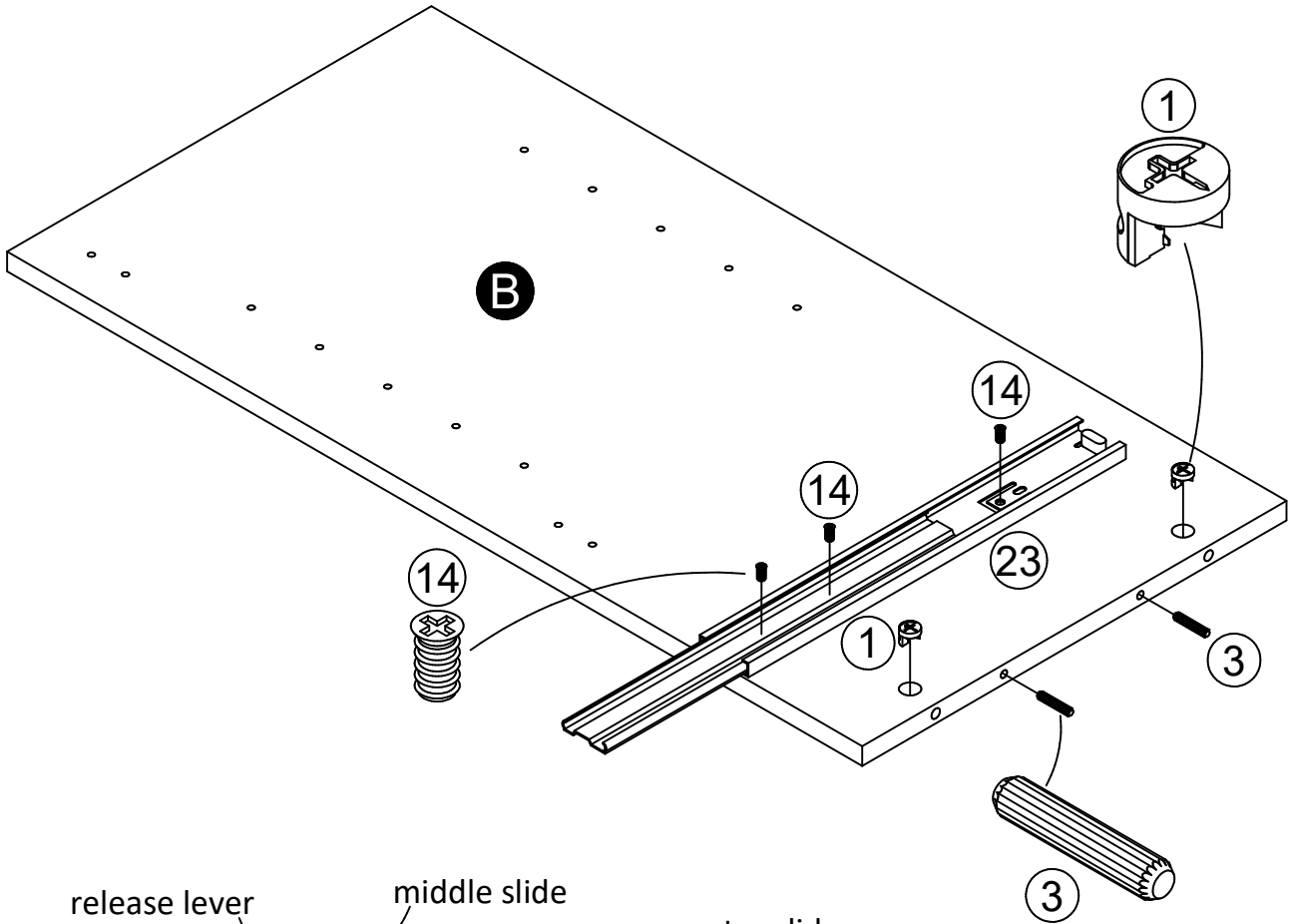
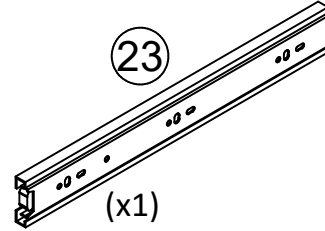
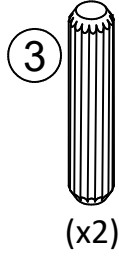
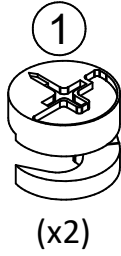
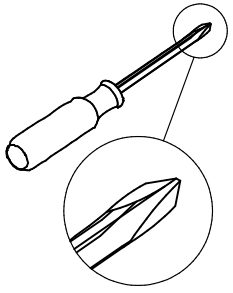

STEP 3

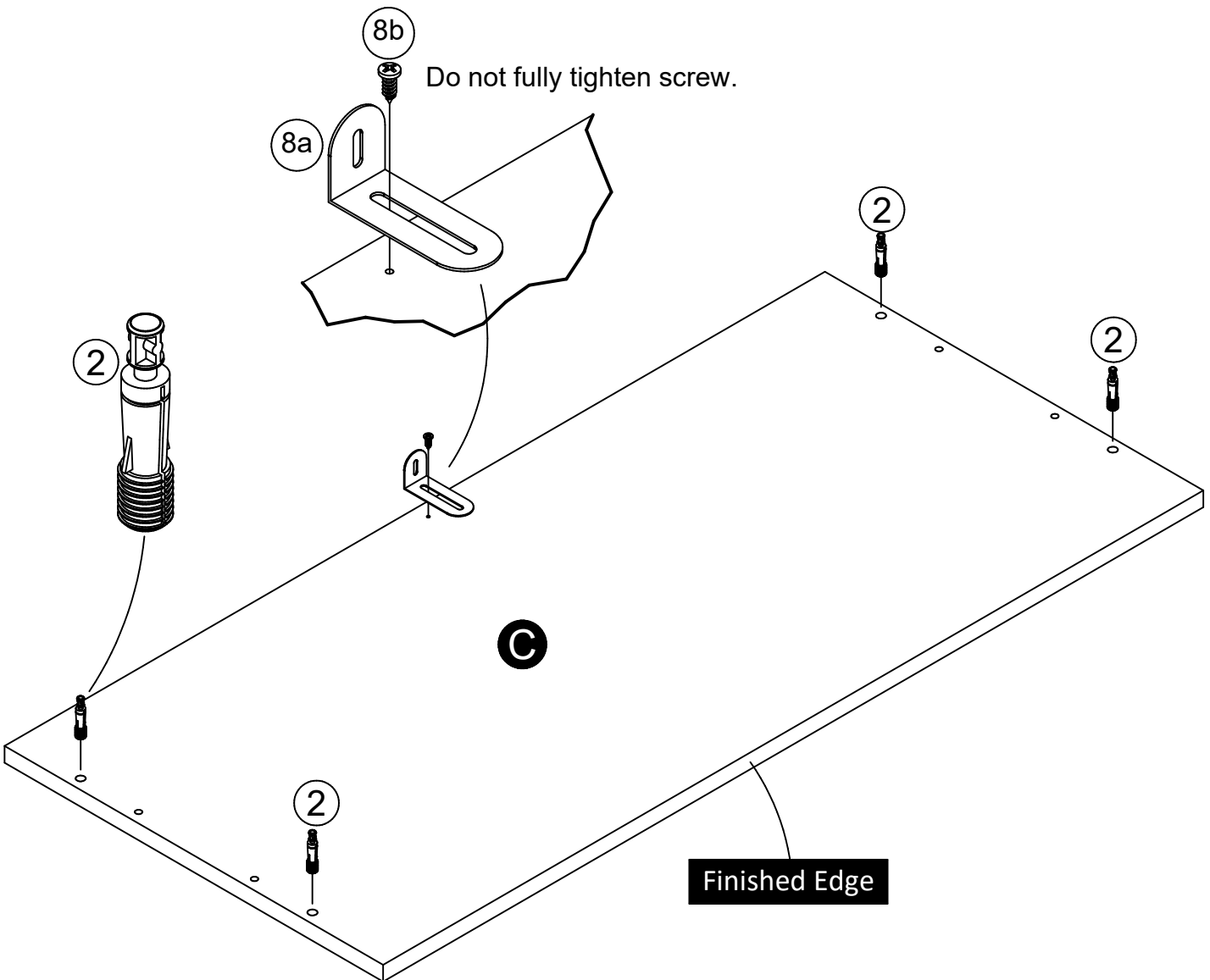
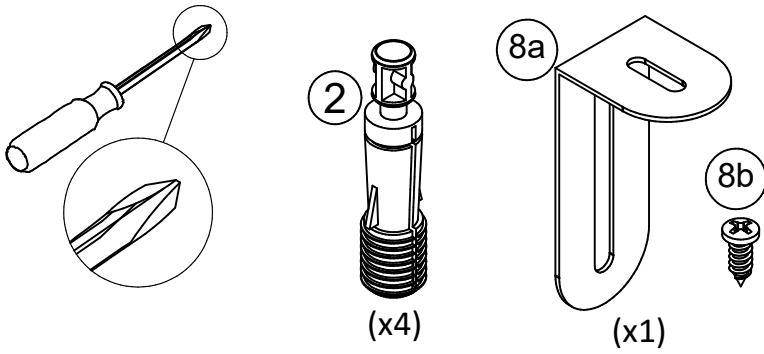

STEP 4

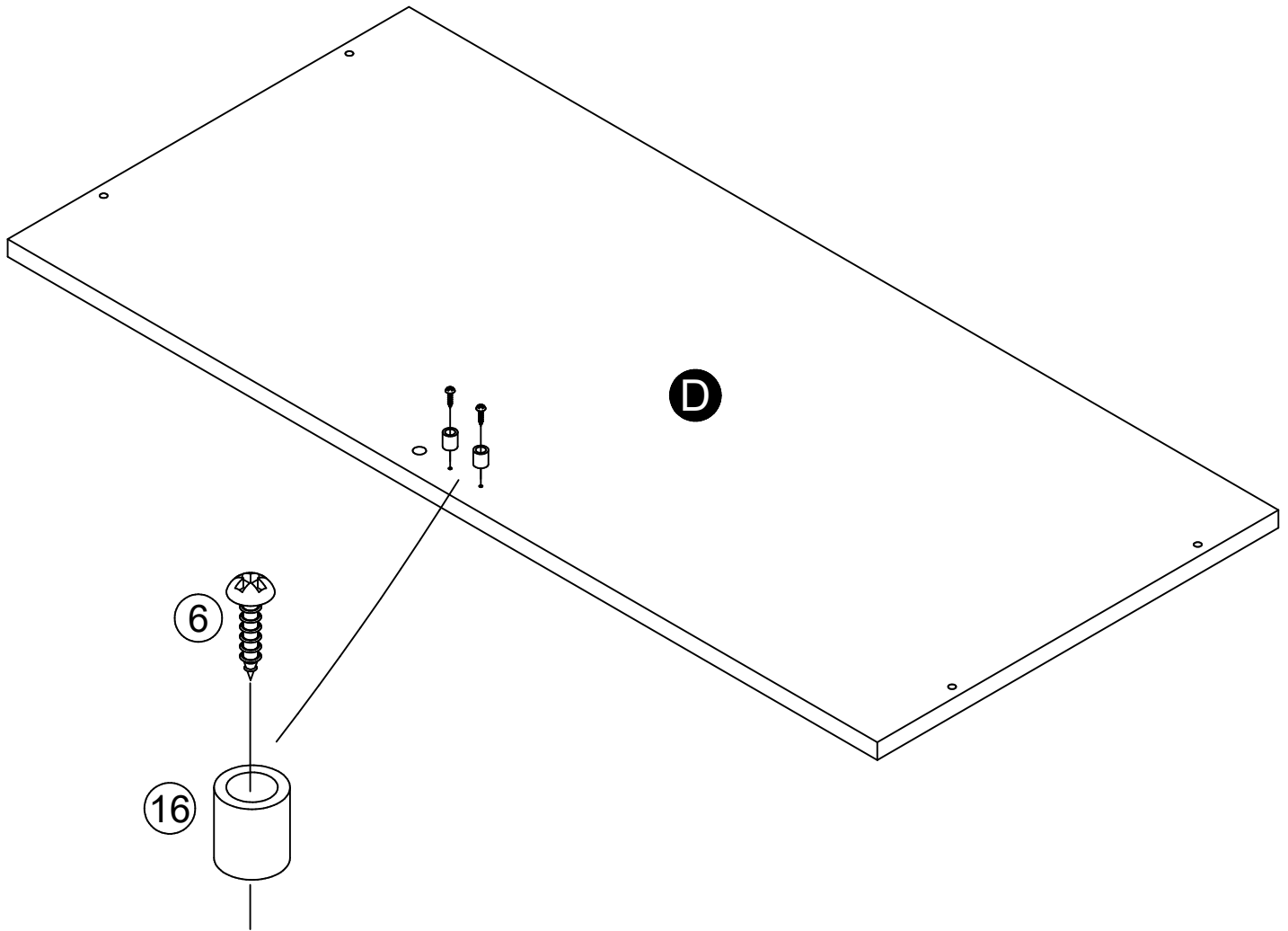
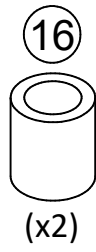
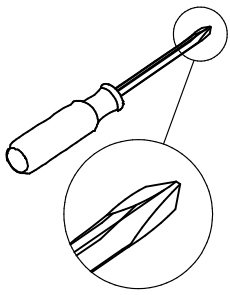

STEP 5

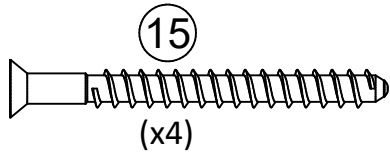
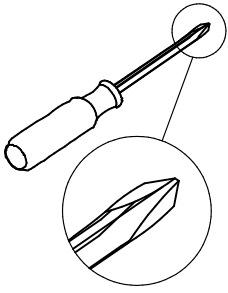

Finished Edges Face Up

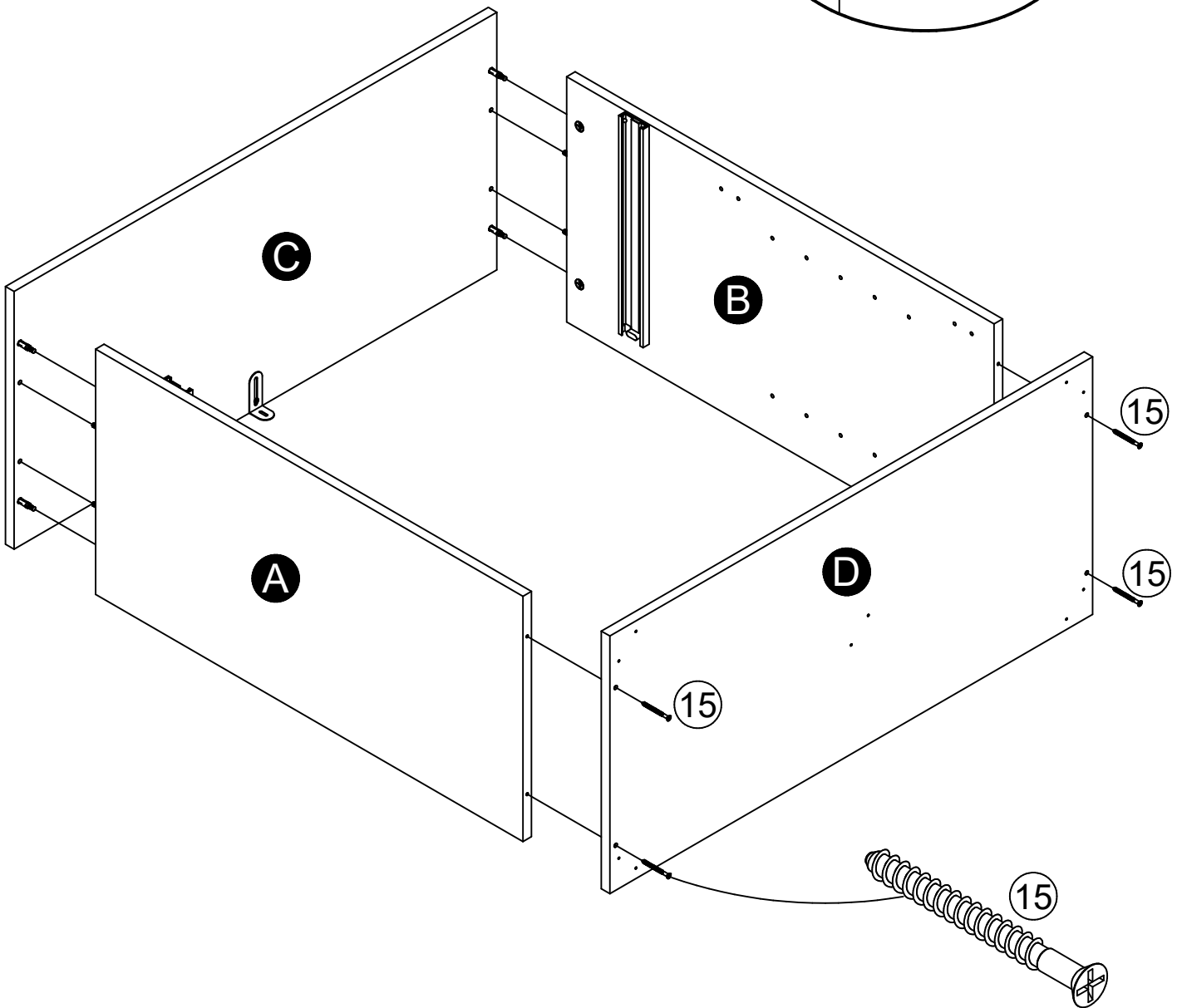
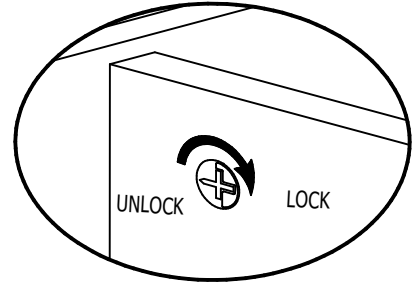

STEP 6

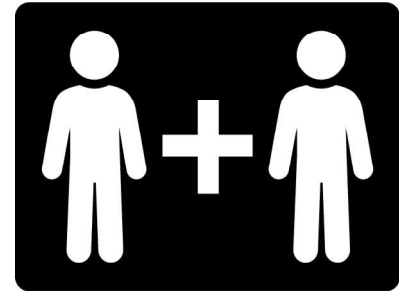
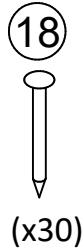
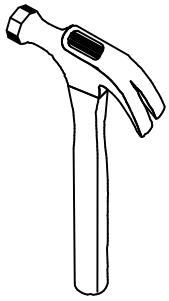

IMPORTANT! THE BACK PANEL IS A STRUCTURAL PART OF THIS UNIT AND MUST BE INSTALLED PROPERLY.
Carefully turn the unit over on its front side.
Position back panel as shown. Align squarely with all edges and nail straight into back edges as shown.

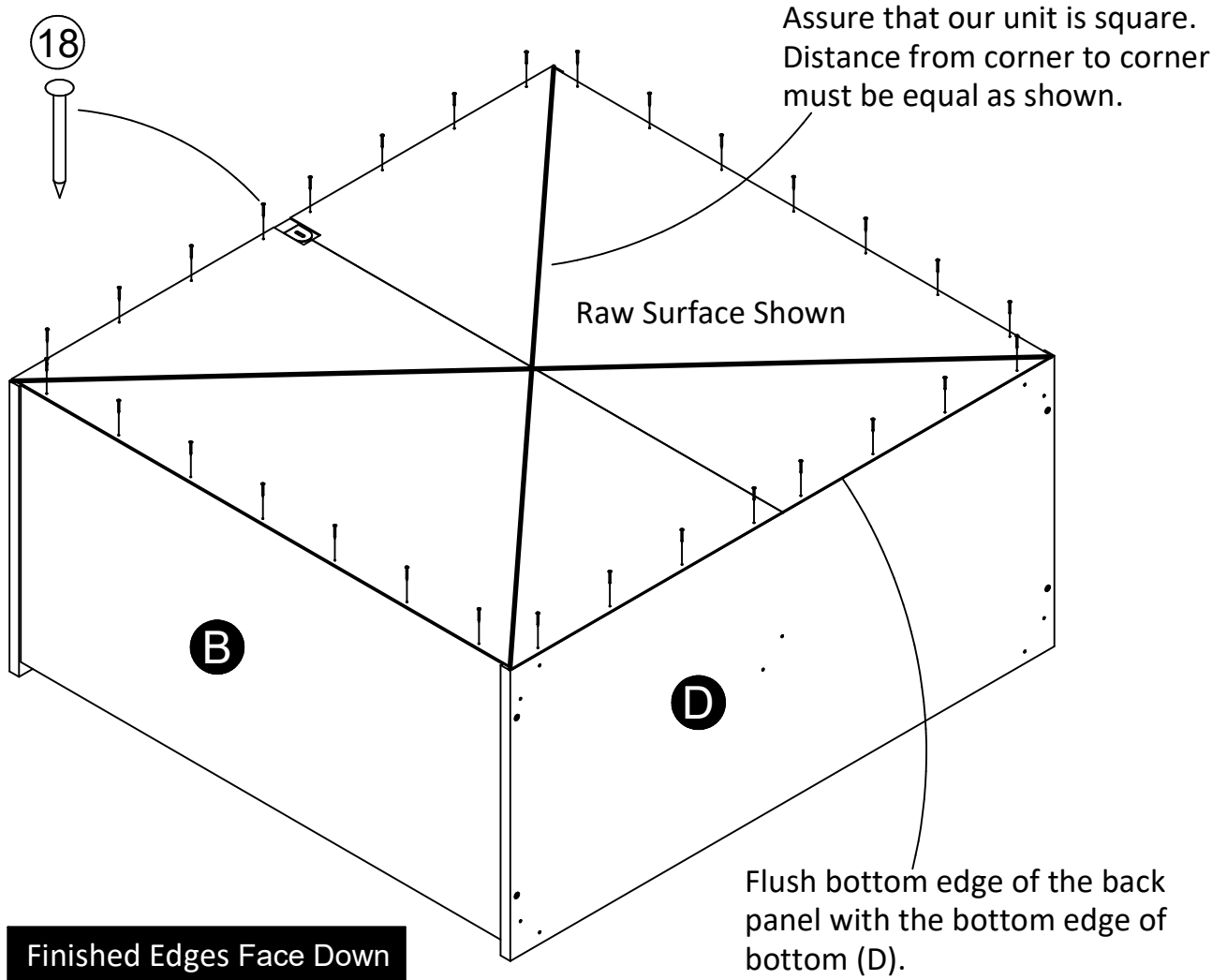

STEP 7

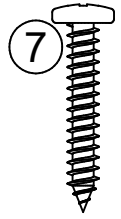
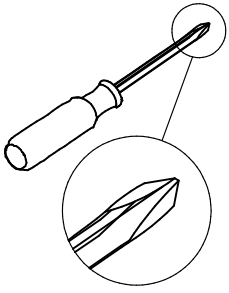

(x10)

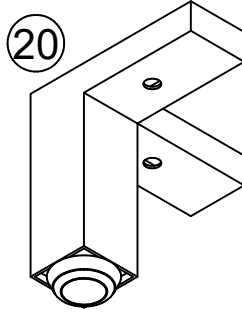

(x5)

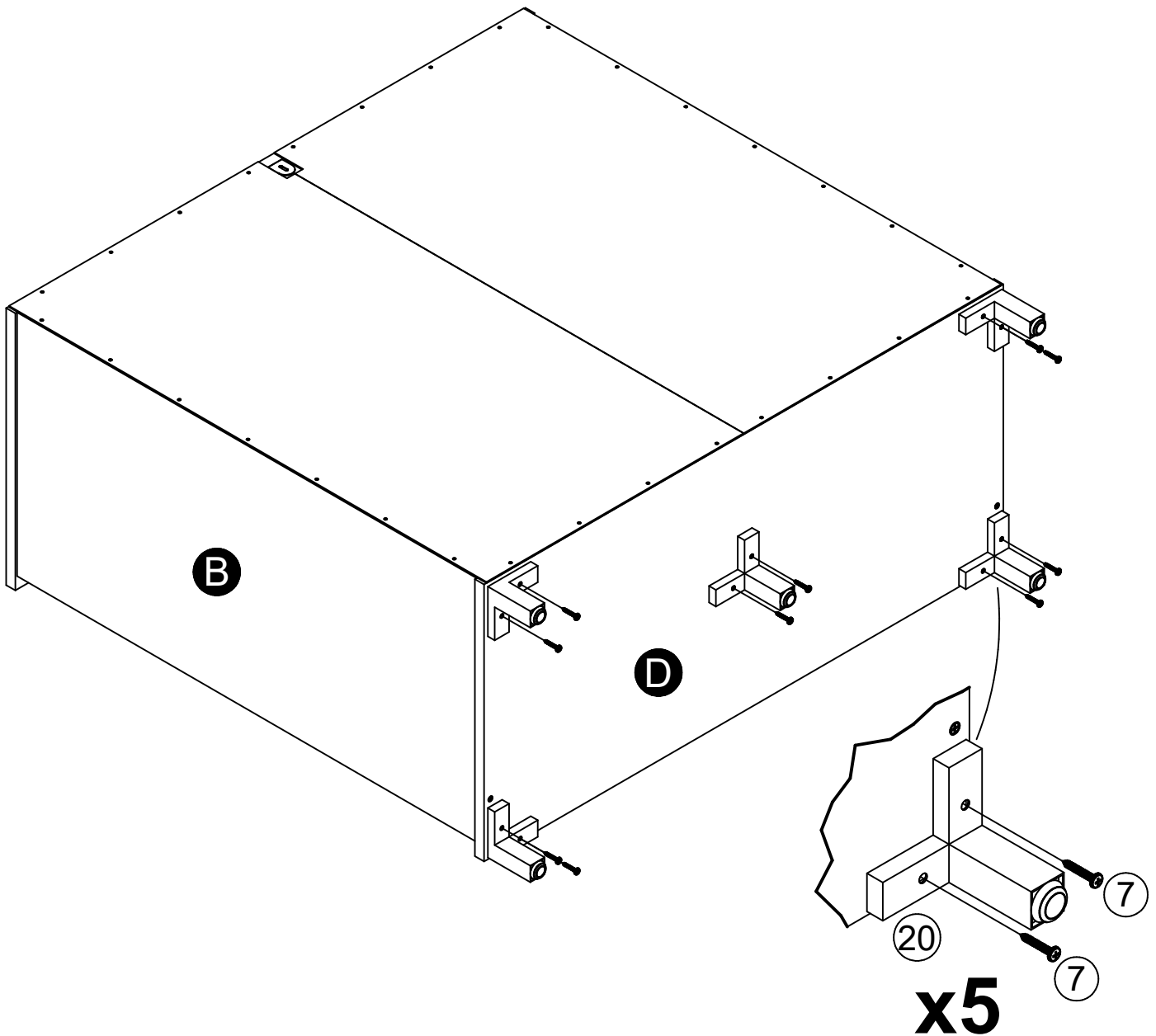

STEP 8

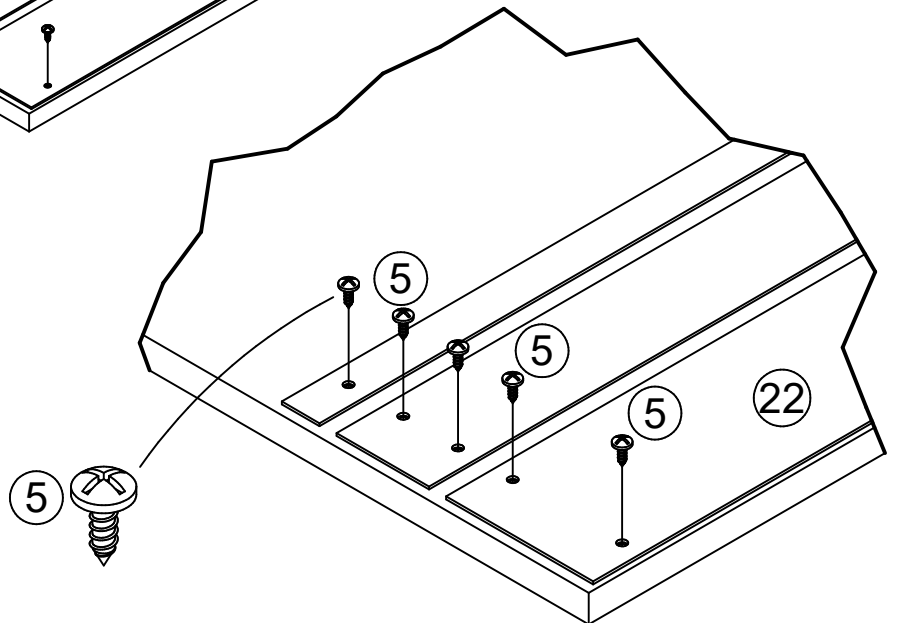
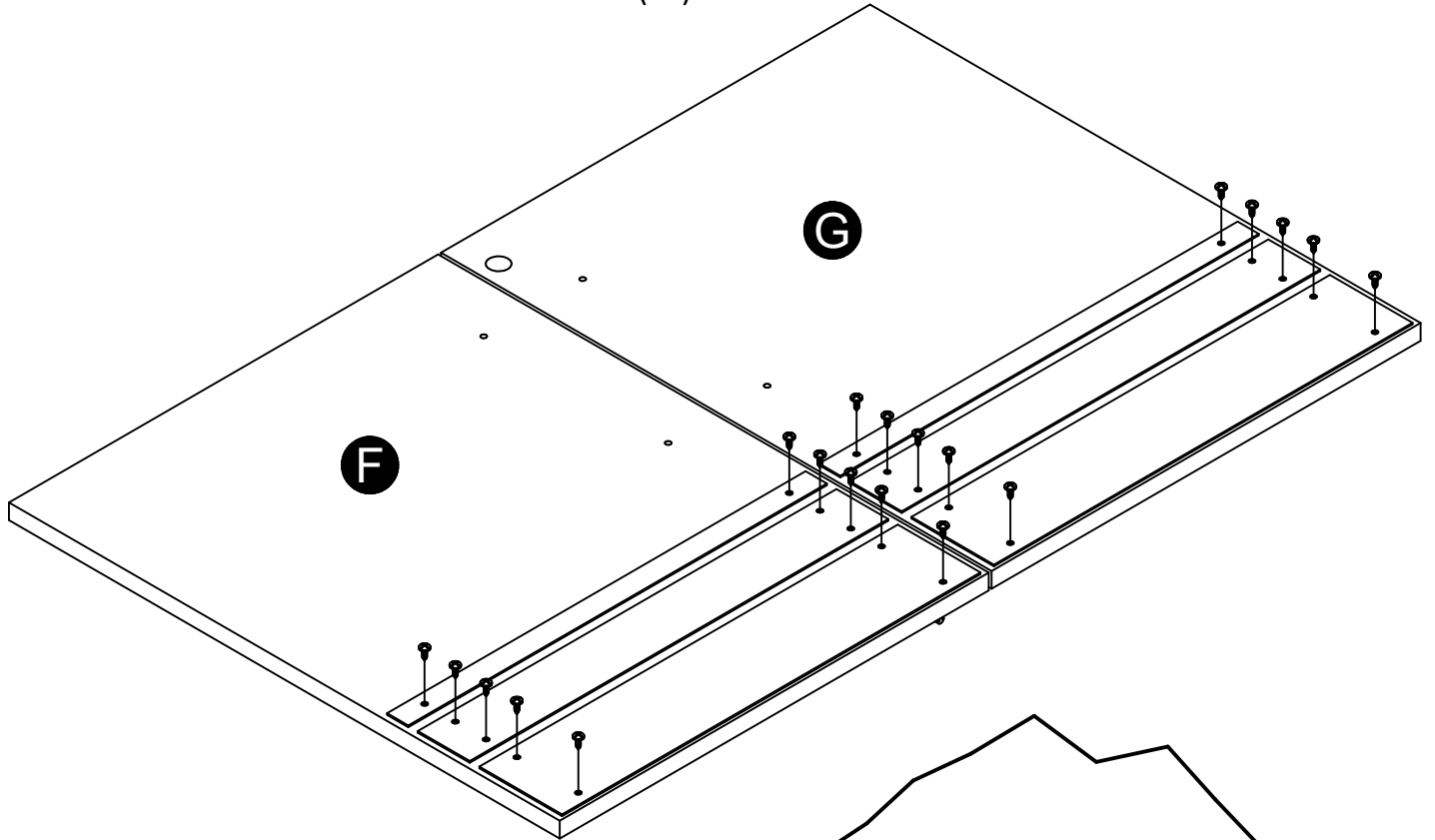
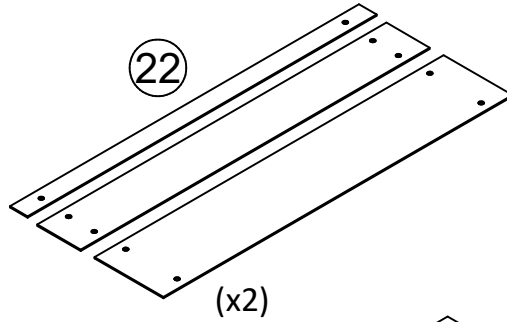
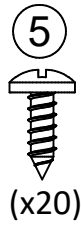
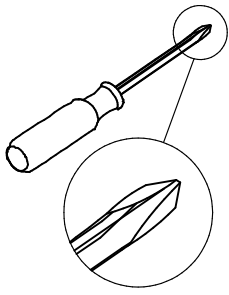

STEP 9

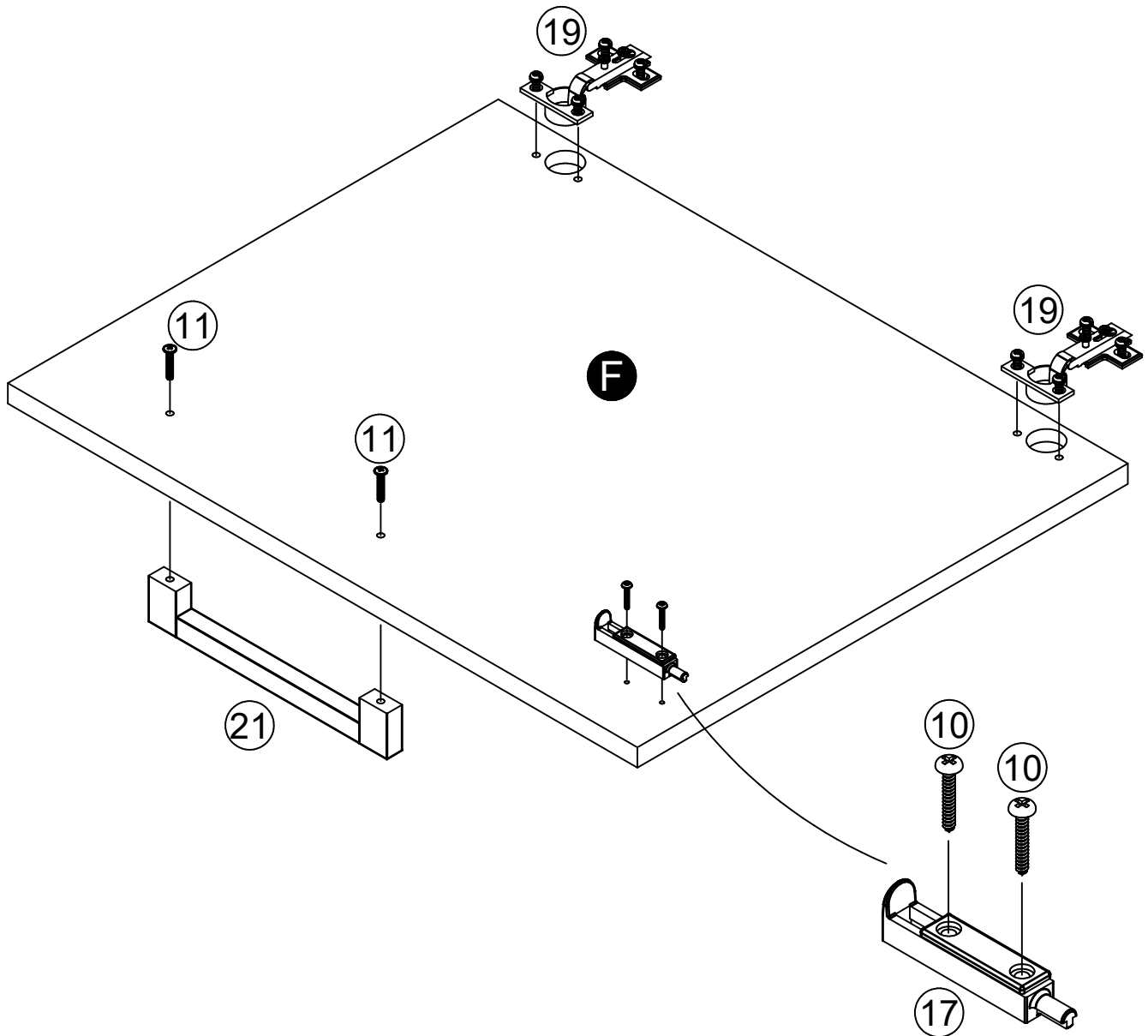
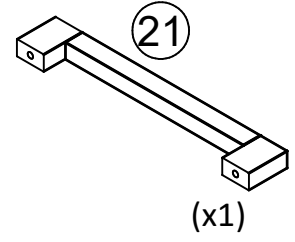
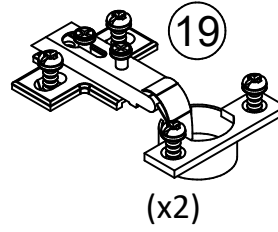
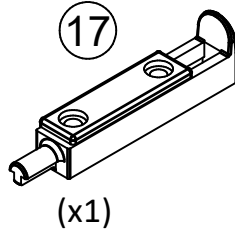
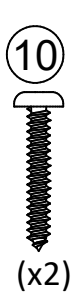
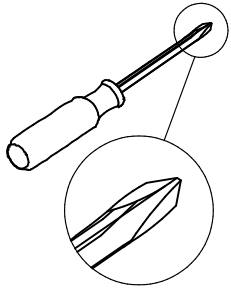

STEP 10

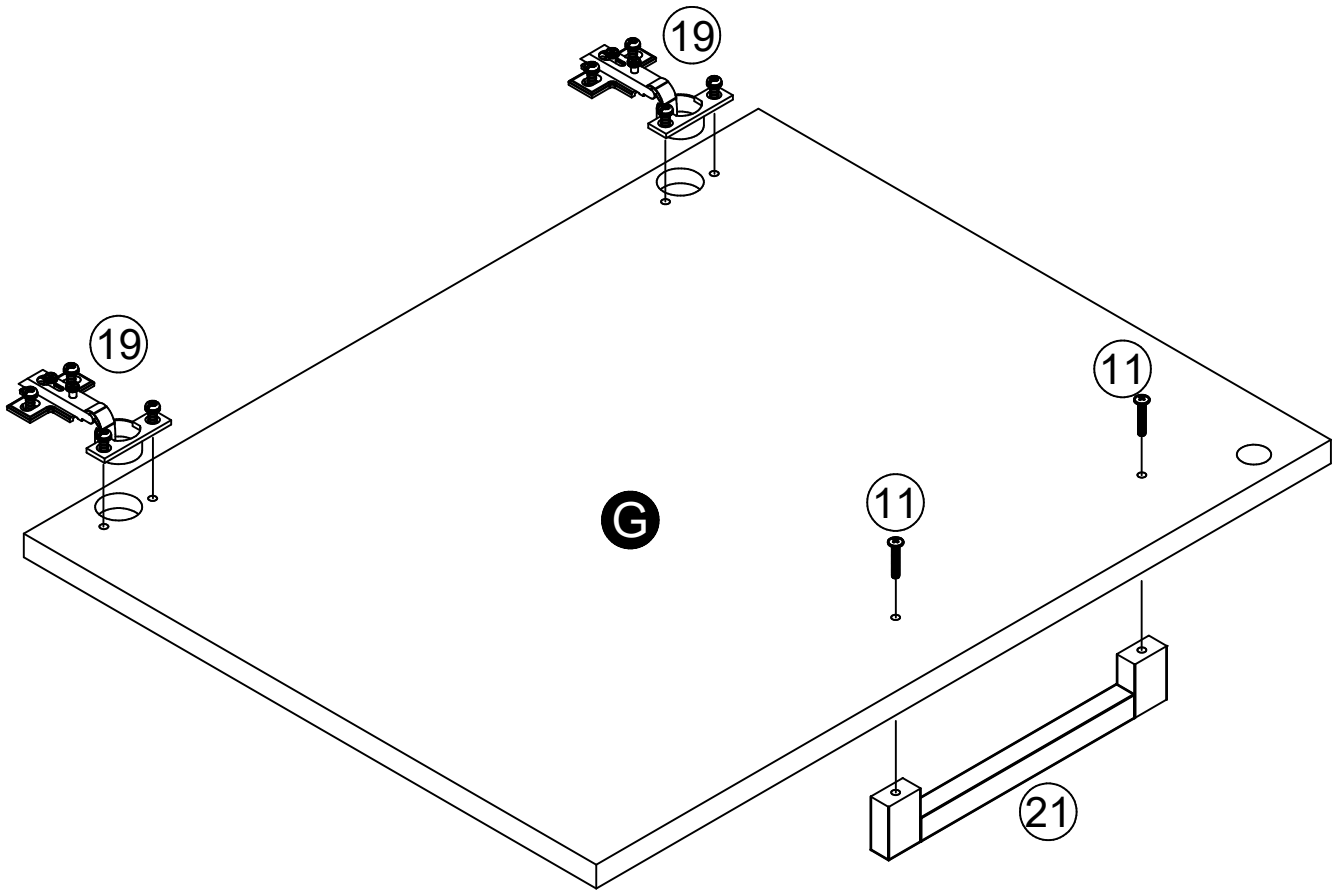
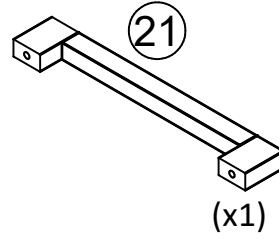
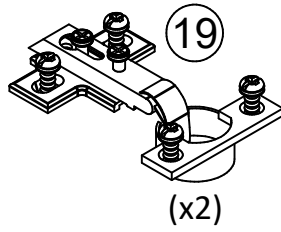
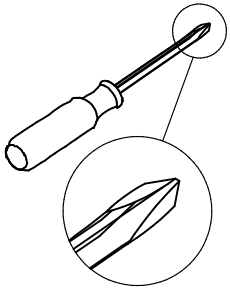

STEP 11

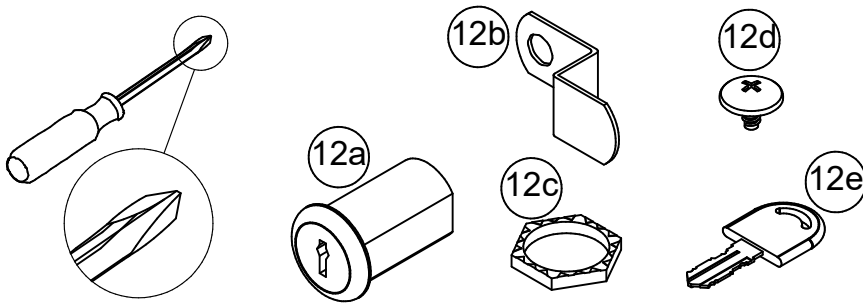

Insert the barrel of the lock (12a) into the hole as shown. With the teeth of the lock nut (12c) facing the door surface, tighten the lock nut (12c). Position lock bar (12b) and attached the barrel of the lock (12a) with the lock screw (12d). Lock bar (12b) will point straight left. When you turn the lock with the key, lock bar will rotate counter-clockwise pointing straight down (unlock position).

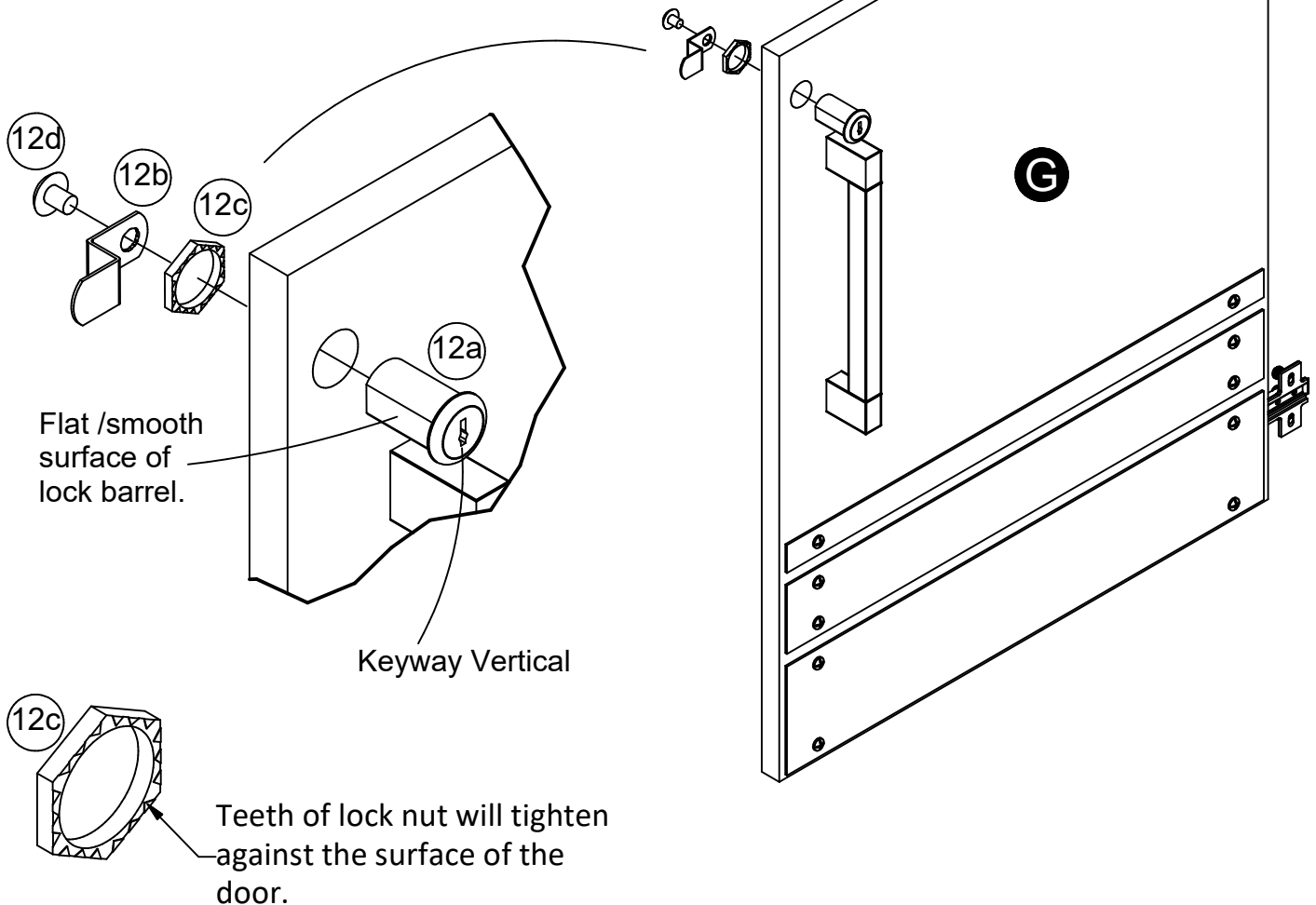

STEP 12

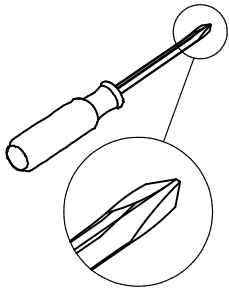

When mounting the left door (F), be sure the slide bolt (17) is positioned in the up position.

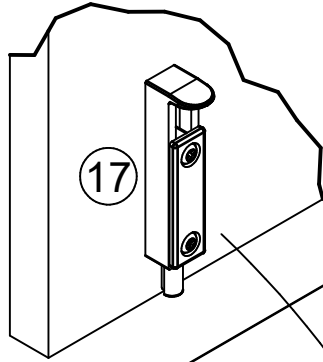

When mounting the right door (G), be sure the lock bar (12b) is pointing straight down.

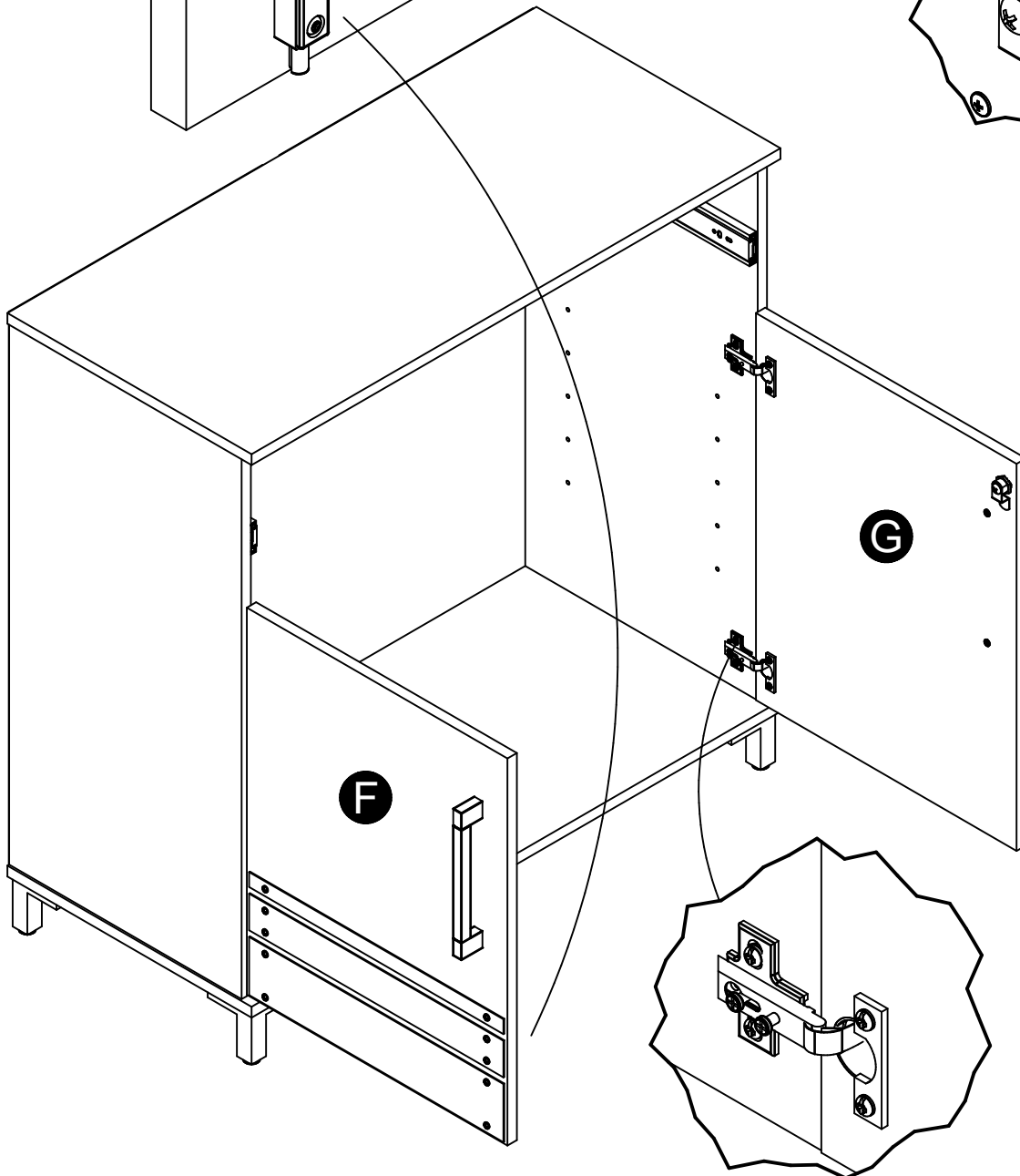
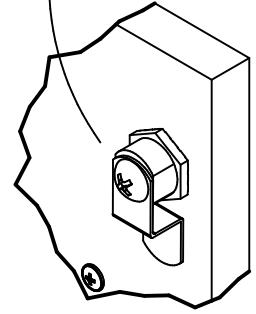

STEP 13

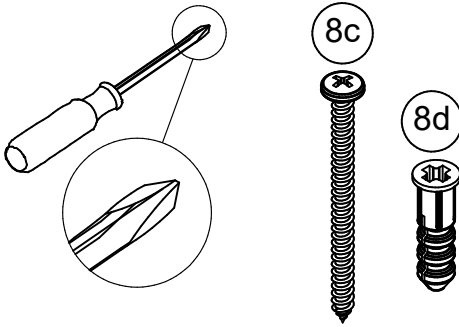

For Masonry, Concrete, or other wall materials:

Consult your local hardware store for appropriate anchors to securely attach the safety bracket.

IMPORTANT: THIS UNIT MUST BE SECURE TO THE WALL TO HELP PREVENT TIPOVER. FOLLOW THESE INSTRUCTIONS TO INSTALL THE ANTI-TIPPING SAFETY BRACKET PROVIDED WITH THIS PRODUCT.

WARNING

Serious or fatal crushing injuries can occur from furniture tipover.

To prevent tipover:

- * Install tipover restraint provided
- * Place heaviest items in the lowest drawers
- * Unless specifically designed to accommodate, do not set TVs or other heavy objects on the top of this product
- * Never allow children to climb or hang on drawers, door, or shelves
- * Never open more than one drawer at a time

Use of tipover restraints may only reduce, but not eliminate the risk of tipover

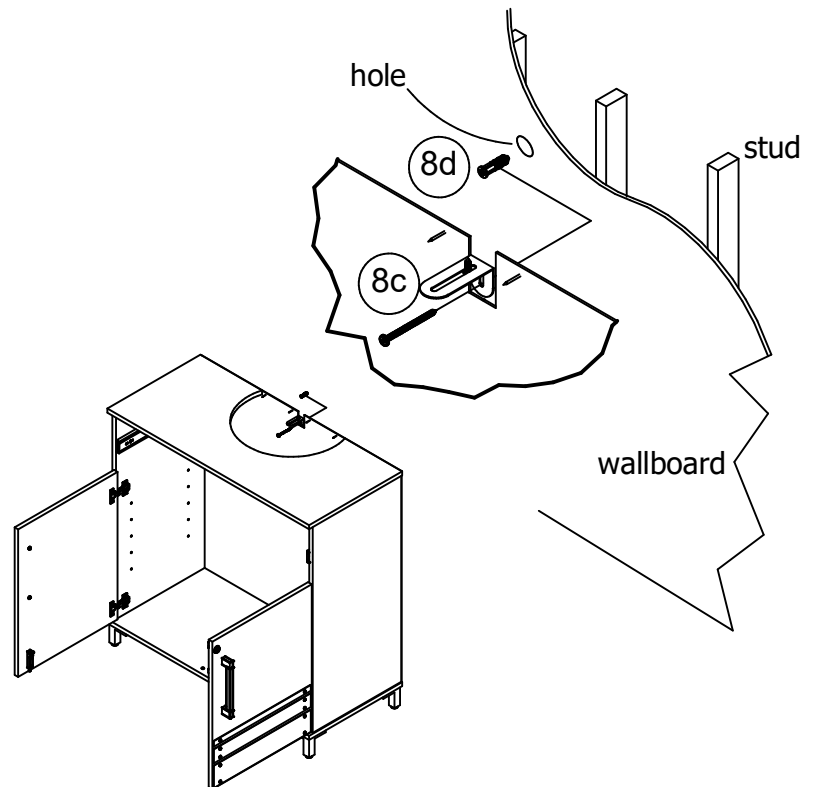

OPTION 1: Attachment into a wall stud (preferred method)

Using a stud finder, locate a stud in the wall. Place your unit against the wall, with the safety bracket aligned in this location. To make driving the screw easier, you can drill a 1/8" diameter pilot hole (3mm) through the safety bracket into the stud. Drive the screw through the safety bracket into the wall stud. Tighten the screw that was not fully tightened in step 3.

OPTION 2: Attachment into drywall

Locate your unit where desired against a wall and mark the wall through the safety bracket, then move your unit aside. Drill a 3/16" diameter hole (5mm) into the wallboard. Tap the wall anchor into the hole until it is flush. Move your unit into location and fasten the wall bracket to the wall anchor with the screw. Tighten the screw that was not fully tightened in step 3.

STEP 14

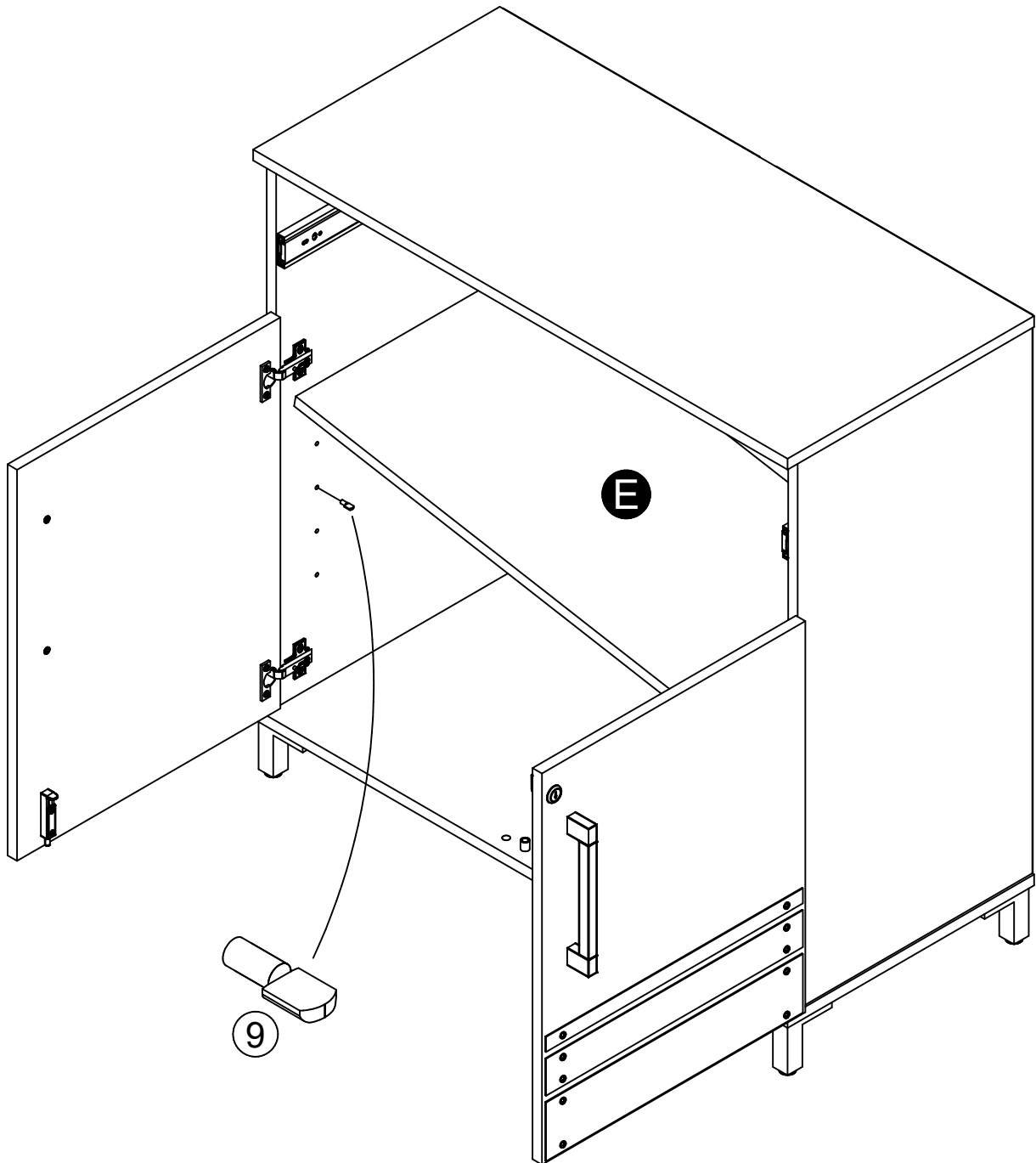
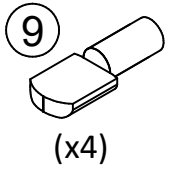

STEP 15

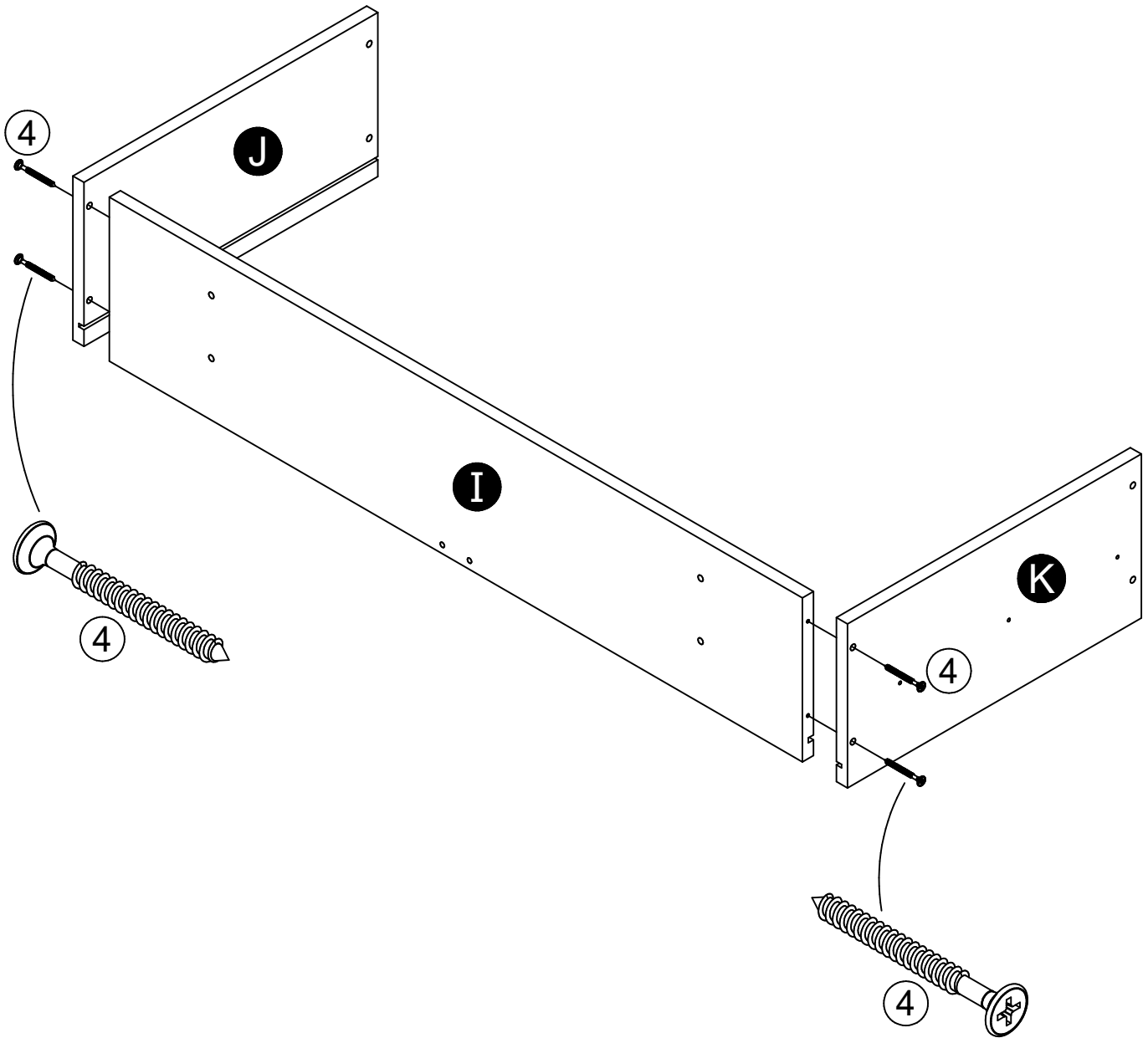
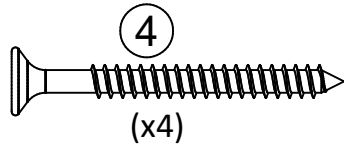
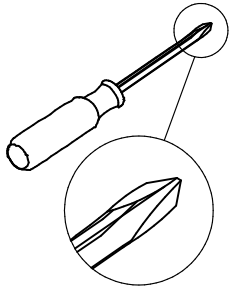

STEP 16

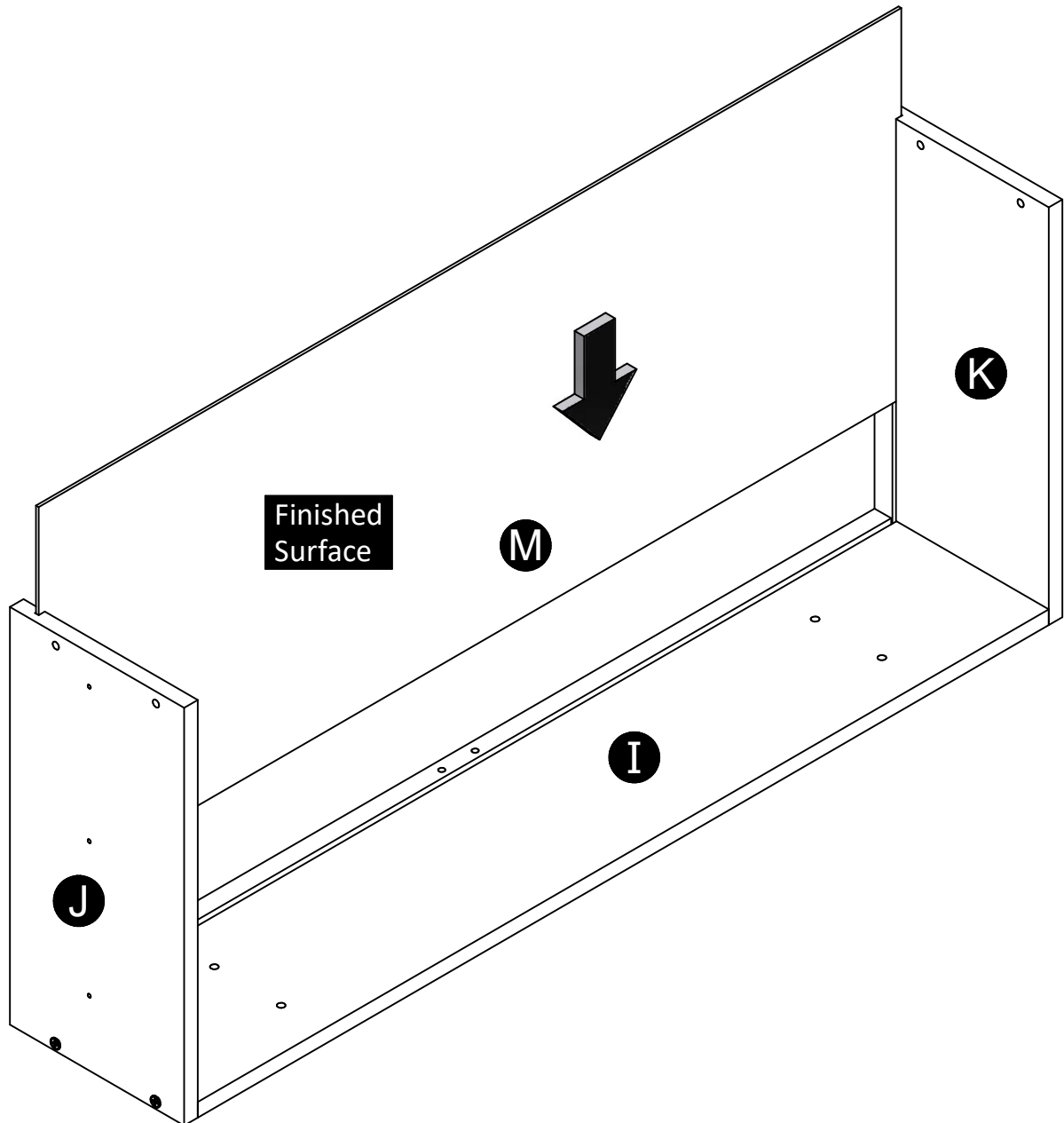

STEP 17

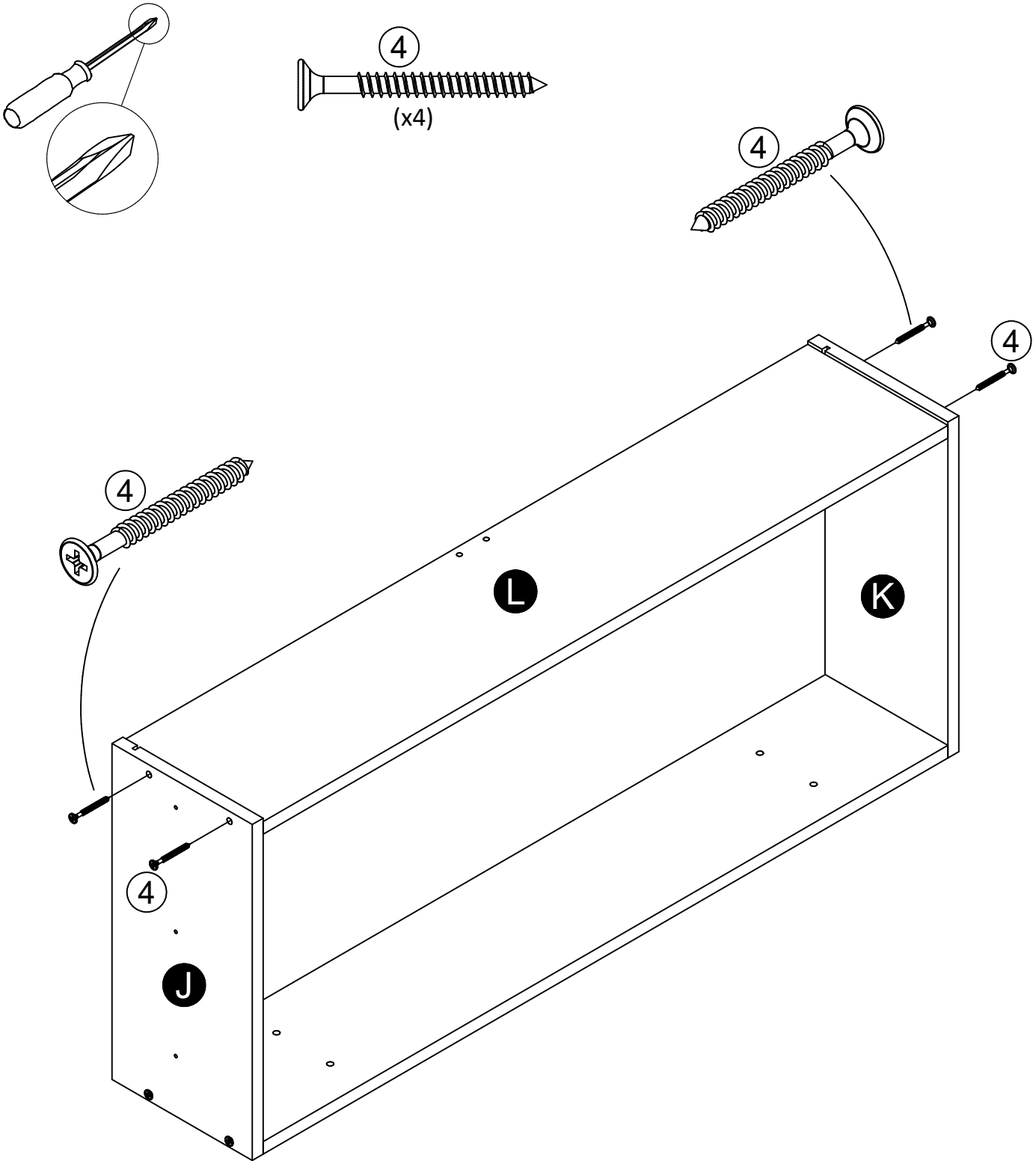

STEP 18

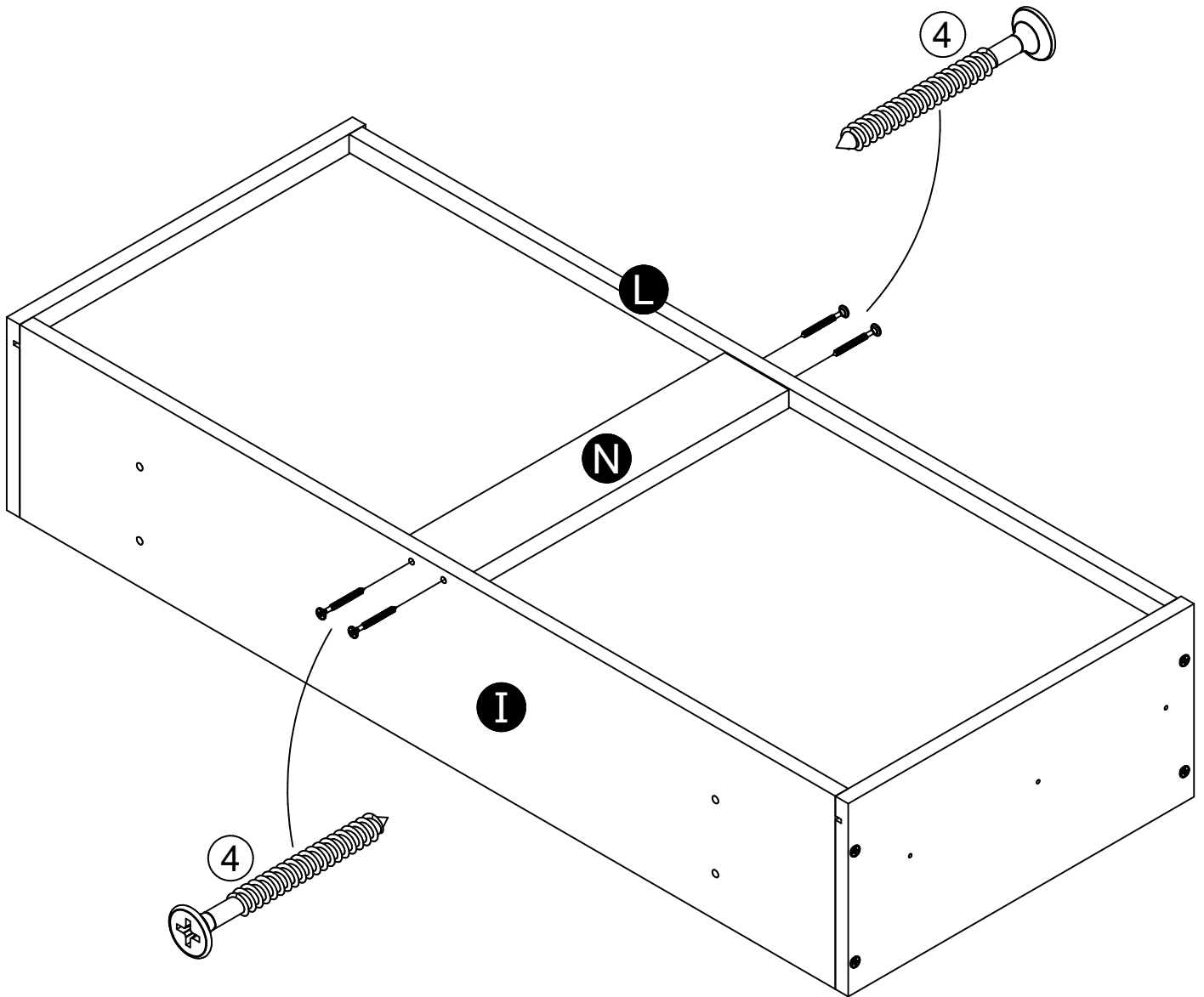
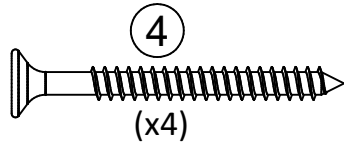
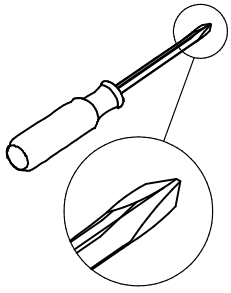

STEP 19

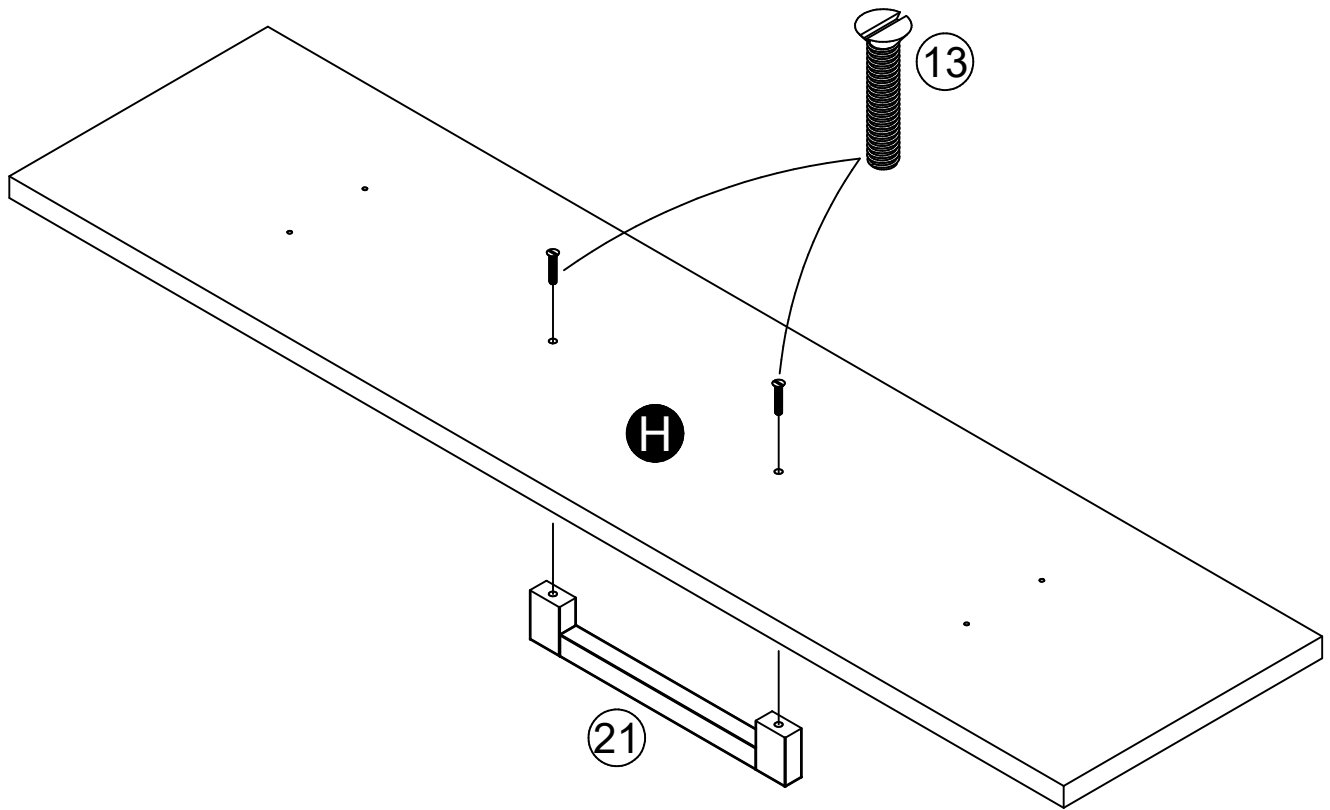
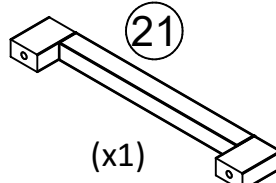
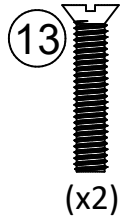
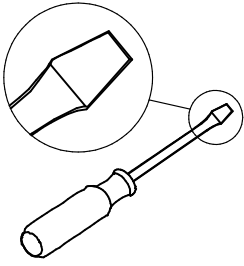

STEP 20

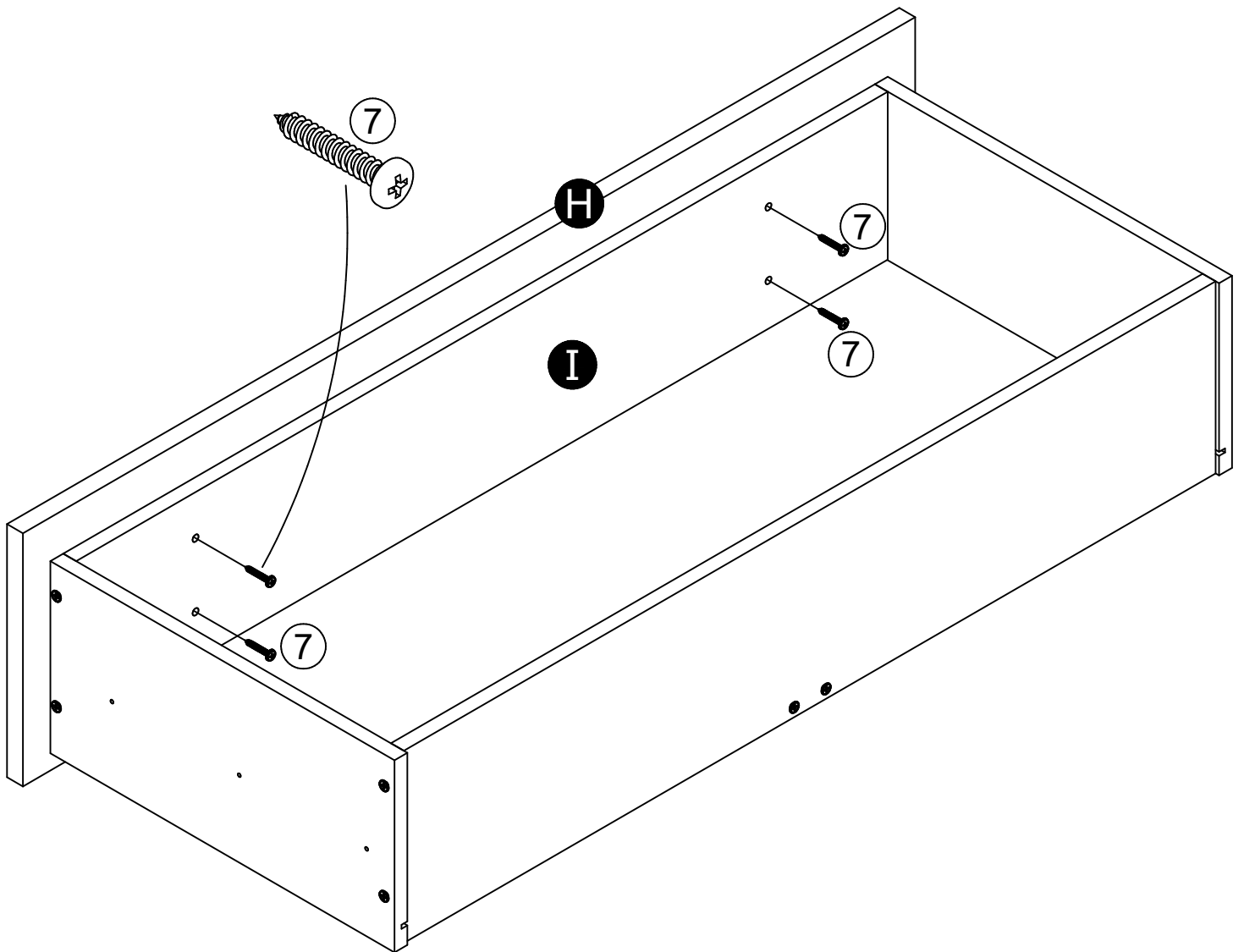
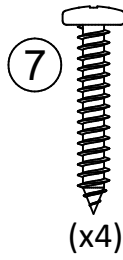
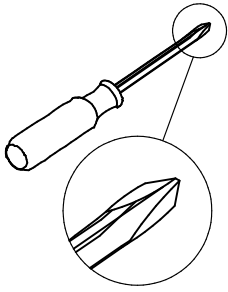

STEP 21

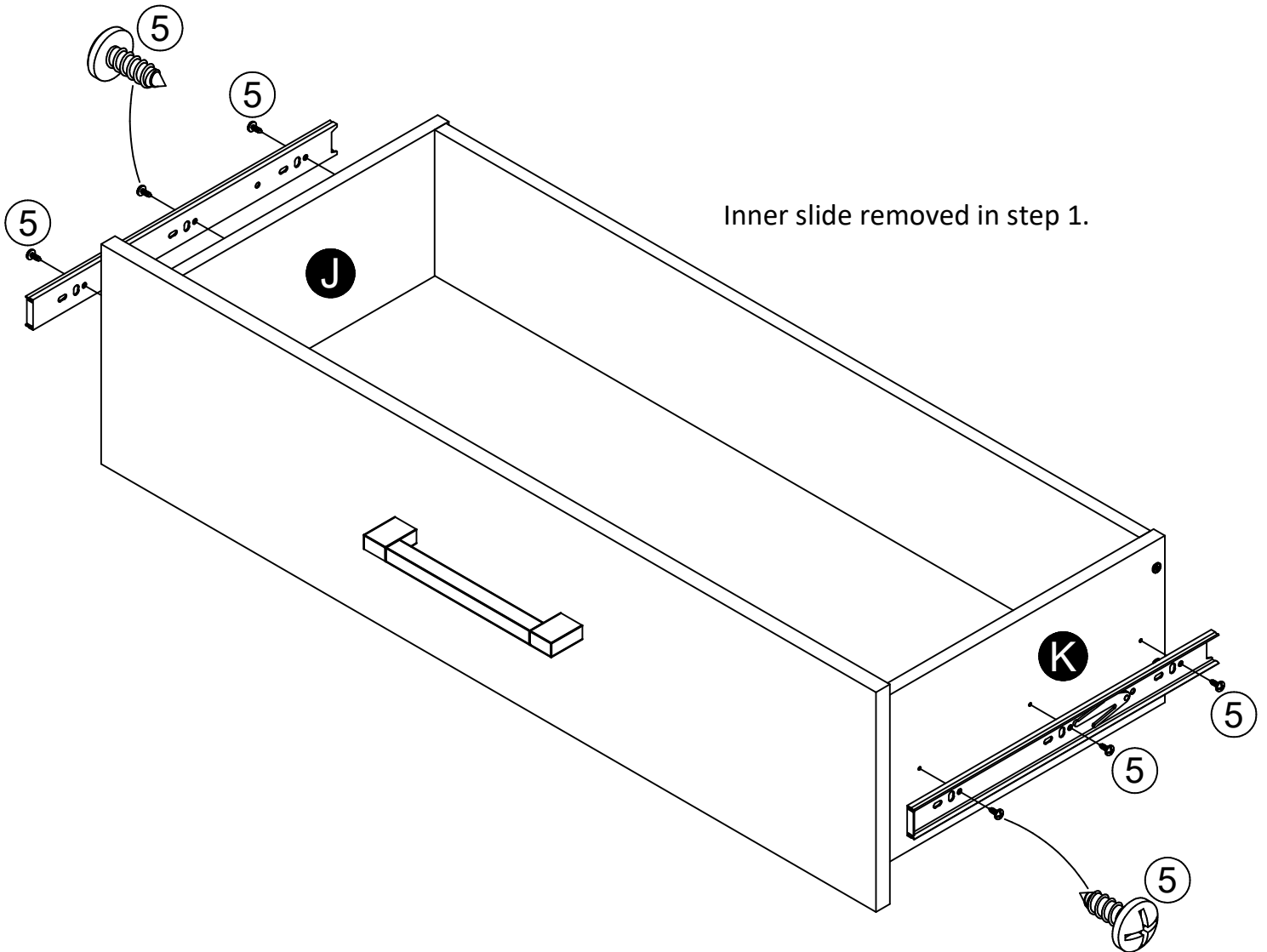
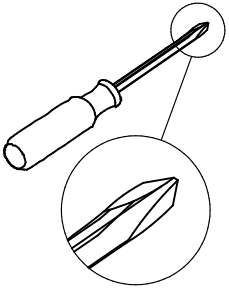

STEP 22

Install the drawer by inserting the inner slide into the track of the middle slide and press completely in.

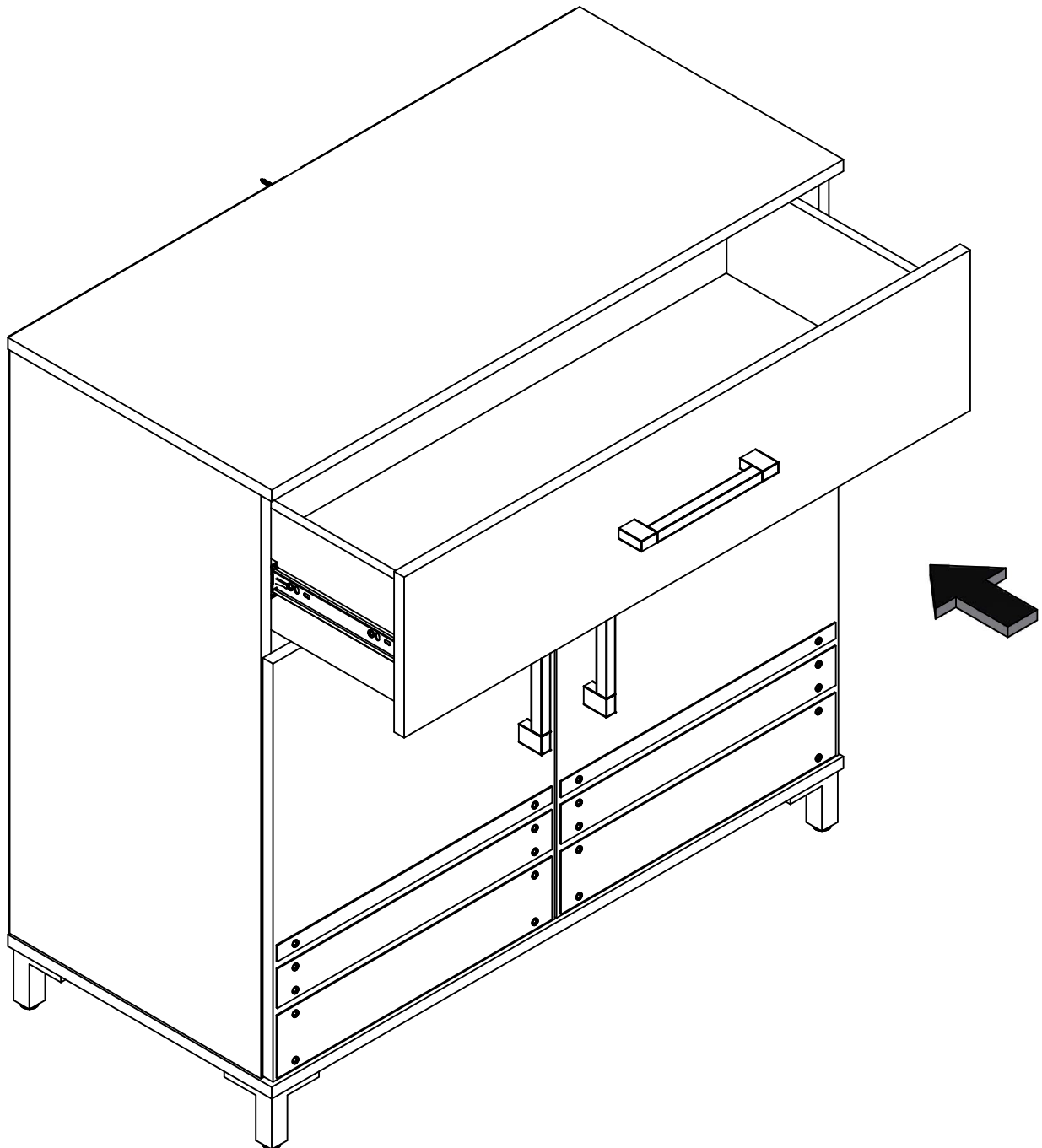

STEP 23

To lock your cabinet:

Shut the left door (F), press the slide bolt (17) down into the hole in the bottom (D). Close the right door (G) and turn the lock (12) so the lock bar rotates to the left and behind the left door (F).

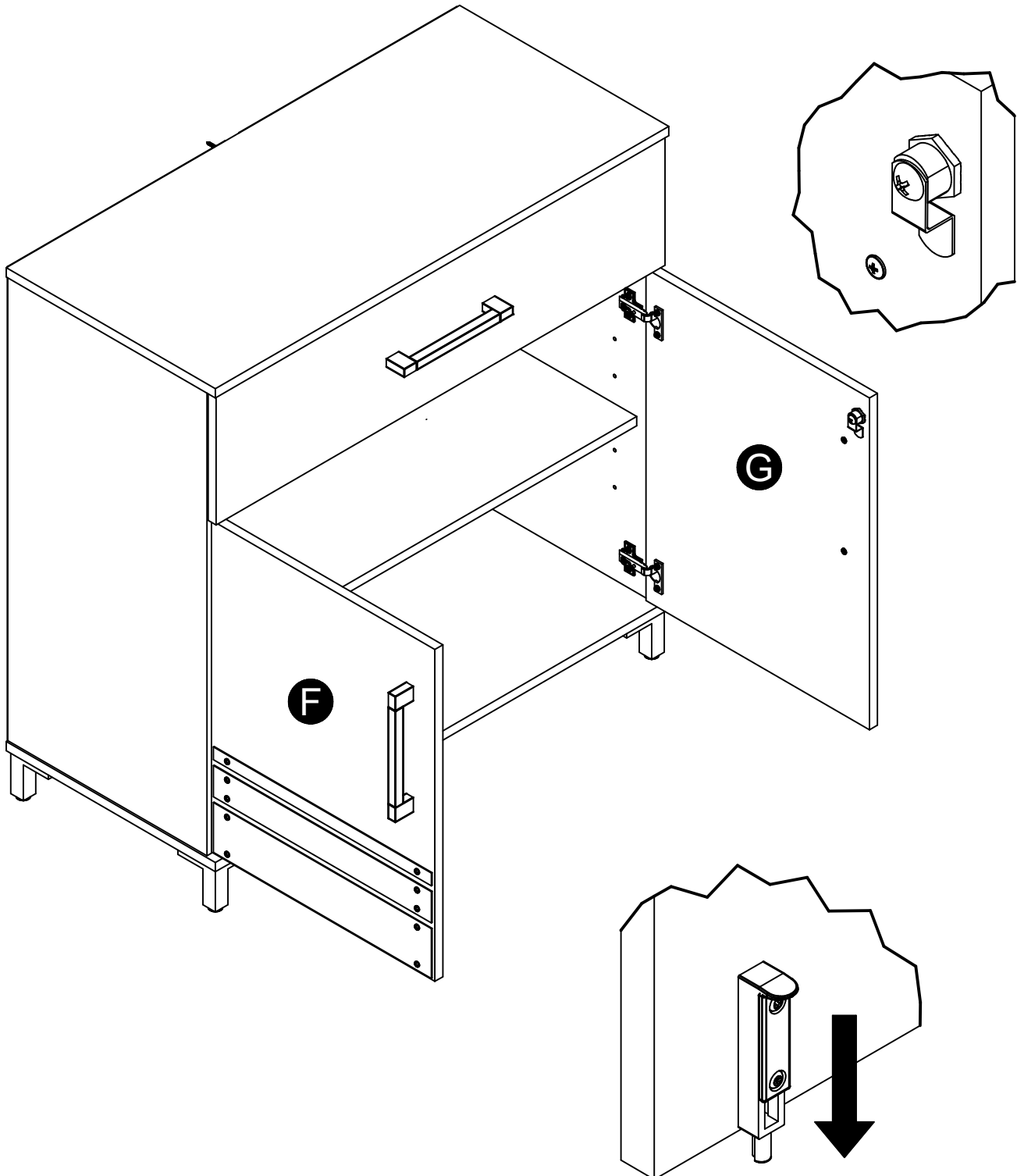

STEP 24

Door Adjustment

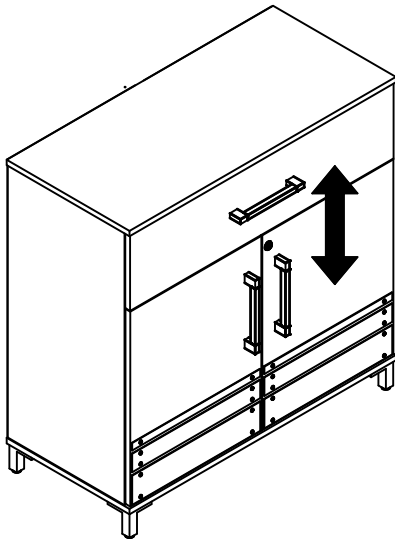
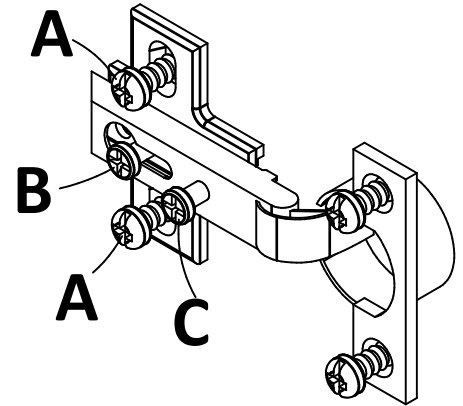
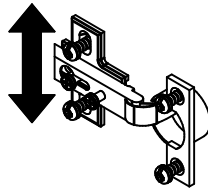
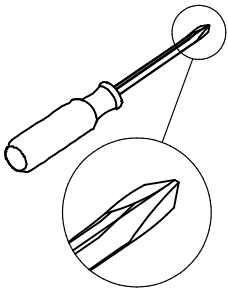

To adjust the vertical height:
Loosen the screws "A" on both hinges. They are usually in slotted holes which allows you to adjust up or down by a few mm. Then tighten back up.

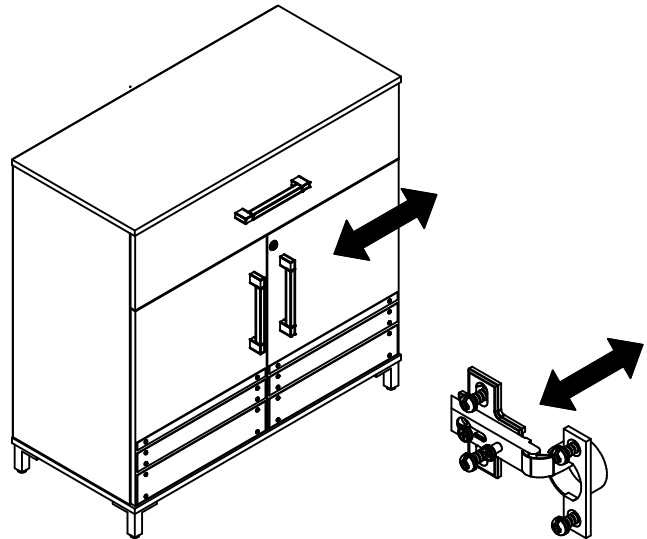

To adjust side to side:
Loosen the screw "C" on BOTH hinges and tighten "B" moves door outward. Loosen "B" and tighten "C" moves doors inward.

To adjust the depth:
Loosen the screw "B" and adjust door.

Maximum Loads

This unit has been designed to support the maximum loads shown. Exceeding these load limits could cause sagging, instability, product collapse, and/or serious injury.

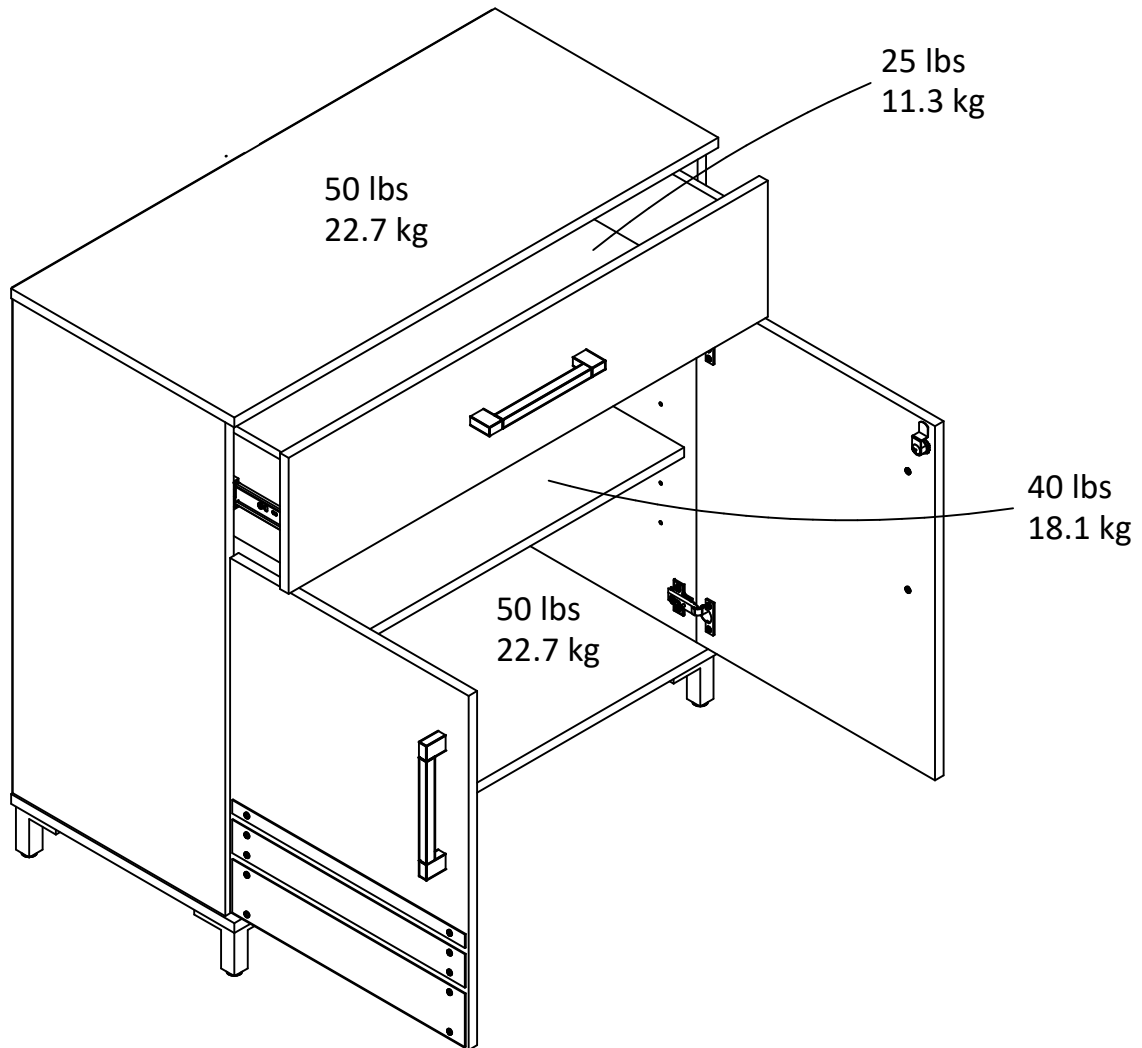

Warning: Risk of injury to persons - do not place a television on this furniture. This furniture is not approved for use with a television.

Certificate of Conformity

1. This certificate applies to the Dorel Home Furnishings, Inc. product identified by this instruction manual.
2. This certificate applies to compliance of this product with the CPSC Ban on Lead-Containing Paint (16 CFR 1303).
3. This product is distributed by: Dorel Home Furnishings, Inc.
410 East First Street South
Wright City, MO 63390
636-745-3351
4. Site of Manufacture: Tiffin OH
5. See front page of instruction manual for date of manufacture.

Register your product to receive the following:



- * New trend details - sneak peek on what's new
- * Surveys - have a voice within our community
- * Exclusive deals and discount codes
- * Quick and easy replacement part service

To register your product, visit ameriwoodhome.com

5 Star Rating



Visit your local retailer's website, rate your purchased product and leave us some feedback!

We would like to extend a big "Thank You" to all of our customers for taking the time to assemble this Ameriwood Home product, and to give us your valuable feedback.

*Thank
You!*

Cubierta Delantera

Este libro de instrucciones contiene información **IMPORTANTE** de seguridad. Por favor lea y manténgalo para referencia en el futuro.

No Regrese este producto! Comuníquese con nuestro amigoso equipo de servicio al cliente para obtener ayuda.

Llámenos al: 1-800-489-3351 (Gratis) Lunes - Viernes 9am - 5pm CST

Visitar: www.ameriwoodhome.com

PRECAUCION

Este mueble puede volcarse y causar graves heridas y/o muerte.

Anclar el mueble a un poste de madera en la pared (si esto se requiere).

No Permita que los niños monten el mueble.

Mantenga los artículos más pesados en los cajones de abajo.

Consejos Útiles (página 2)

- Abra su artículo en el área donde usted planea utilizarlo para evitar levantar y moverlo menos
- Identificar, ordenar y contar las piezas antes de intentar ensamblar
- Las clavijas de compresión se golpean con un martillo
- Las diapositivas están marcadas con una R (derecha) y L (izquierda) para la colocación correcta
- Asegúrese de que siempre este el punto localizado en la parte superior de bloqueador de leva este volteado hacia borde exterior
- Utilizar todos los clavos para el panel de atrás y distribuirlos por igual
- El panel de atrás debe utilizarse para asegurarse de que la unidad quede fija y firme
- No use químicas fuertes ni limpiadores abrasivos en este artículo
- Nunca empuje, tire ni arrastre los muebles

Antes de Que Empieces (página 3)

- Lea cuidadosamente cada paso y siga el orden correcto
- Separar y contar todas sus piezas y hardware
- Dése suficiente espacio para el proceso de ensamble
- Tenga las siguientes herramientas: destornillador de cabeza plana, #2 cabeza Phillips Destornillador y martillo
- Precaución: Si usa un taladro electrónico o un destornillador eléctrico para atornillar, por favor asegúrese que deje de atornillar cuando el tornillo este apretado. Fallar hacer esto puede causar barrer el tornillo.

Sistema de fijar el bloqueo de leva (página 3)

Este sistema de fijar el bloqueo de leva será usado en todo el proceso de ensamble.

Página 9

Localice el kit de deslizamiento (21). Extienda la corredera como se muestra y presione la palanca de liberación para retirar la corredera interior. Deje la corredera interior a un lado para más tarde. Comience por fijar la corredera a los paneles en la parte trasera de la corredera. Mientras se desliza la corredera central, localice los orificios de los paneles con el orificio de acceso de la corredera central y fíjelos con tornillos (20) como se muestra.

Palanca de liberación Corredera del medio Corredera exterior Corredera interior Utilice estos agujeros Agujero de acceso

Página 11

No apriete completamente el tornillo.

Página 14

¡IMPORTANTE! EL PANEL TRASERO ES UNA PARTE ESTRUCTURAL DE ESTA UNIDAD Y DEBE SER INSTALADO CORRECTAMENTE.

Gire con cuidado la unidad sobre su lado frontal.

Coloque el panel trasero como se muestra. Alinee en ángulo recto todos los bordes y clávelos en los bordes traseros como se muestra.

Asegúrese de que nuestra unidad esté cuadrada.

La distancia de esquina a esquina debe ser igual como se muestra.

Enrasar el borde inferior del panel trasero con el borde inferior del fondo (D).

Página 19

Introduzca el cilindro de la cerradura (12a) en el orificio como se muestra. Con los dientes de la tuerca de la cerradura (12c) orientados hacia la superficie de la puerta, apriete la tuerca de la cerradura (12c). Coloque la barra de bloqueo (12b) y fije el cilindro de la cerradura (12a) con el tornillo de bloqueo (12d). La barra de la cerradura (12b) apuntará directamente hacia la izquierda. Al girar la cerradura con la llave, la barra de la cerradura girará en sentido contrario a las agujas del reloj apuntando directamente hacia abajo (posición de apertura).

Superficie plana / lisa del cilindro de la cerradura.

Cerradura vertical

Los dientes de la tuerca de seguridad se apretarán contra la superficie de la puerta.

Página 20

Al montar la puerta izquierda (F), asegúrese de que el pestillo de deslizamiento (17) esté colocado en la posición superior.

Al montar la puerta derecha (G), asegúrese de que la barra de bloqueo (12b) esté orientada hacia abajo.

Página 21

OPCIÓN 1: Fijación en un montante de la pared (método preferido)

Con un detector de montantes, localice un montante en la pared. Coloque su unidad contra la pared, con el soporte de seguridad alineado en esta ubicación. Para facilitar la colocación del tornillo, puede perforar un agujero piloto de 1/8" de diámetro (3 mm) a través del soporte de seguridad en el montante. Introduzca el tornillo a través del soporte de seguridad en el montante de la pared. Apriete el tornillo que no se haya apretado del todo en el paso 3.

OPCIÓN 2: Fijación en una pared de yeso

Ubique su unidad en el lugar deseado contra una pared y marque la pared a través del soporte de seguridad, luego mueva su unidad a un lado. Perfore un agujero de 3/16" de diámetro (5mm) en la pared. Inserte el anclaje de pared en el agujero hasta que quede al ras. Mueva su unidad a su ubicación y fije el soporte de pared al anclaje de pared con el tornillo. Apriete el tornillo que no se haya apretado del todo en el paso 3.

Página 30

Instale el cajón introduciendo la corredera interior en la ranura de la corredera central y presione completamente.

Página 31

Para cerrar el armario:

Cierre la puerta izquierda (F), presione el pestillo deslizante (17) hacia abajo en el agujero del fondo (D). Cierre la puerta derecha (G) y gire la cerradura (12) para que la barra de bloqueo gire hacia la izquierda y detrás de la puerta izquierda (F).

Página 32

Para ajustar la altura vertical:

Afloje los tornillos "A" en ambas bisagras. Por lo general, están en agujeros ranurados que le permite ajustar hacia arriba o hacia abajo por unos pocos mm. A continuación, apriete de nuevo.

Para ajustar la profundidad:

Afloje el tornillo "B" y ajuste la puerta.

Para ajustar de lado a lado:

Afloje el tornillo "C" en ambas bisagras y apriete el "B" mueve la puerta hacia afuera. Afloje el "B" y apriete el "C" mueve las puertas hacia adentro.

Página 33

CARGA MAXIMA

Esta unidad ha sido diseñada para soportar la carga máxima anotada. El exceder estos límites puede causar inestabilidad, colapsarse y/o causar serias lesiones.

ADVERTENCIA: Riesgo de lesiones a las personas - no coloque un televisor sobre muebles. Este mueble no está aprobado para su uso con un televisor.

Página 34

Registre su producto para recibir lo siguiente:

- * Detalles de nuevas tendencias - Vistazo a lo nuevo
- * Encuestas - alec su voz entre su comunidad
- * Códigos de ofertas y descuentos exclusivos
- * Fácil y rápido servicio de partes de remplace

Para registrar su producto, visite ameriwoodhome.com

Clasificación de 5 estrellas

Visite el sitio web de su tienda local, califique su comprado y denos sus comentarios!

Nos gustaría enviar un gran "Agradecimiento" a todos nuestros clientes por tomarse el tiempo de ensamblar este producto de Ameriwood Home, y por darnos sus valiosos comentarios.

Gracias

Couverture Avant

CE LIVRET D'INSTRUCTION CONTIENT DES INFORMATIONS **IMPORTANTES** SUR LA SÉCURITÉ. VEUILLEZ LIRE ET GARDER POUR UNE RÉFÉRENCE FUTURE

Ne retournez pas ce produit! Contactez notre équipe de service à la clientèle amicale d'abord pour obtenir de l'aide.

Appelez-nous: 1-800-489-3351 (sans frais) du Lundi au Vendredi de 9h à 17h Heure Centrale

Visitez: www.ameriwoodhome.com

ATTENTION

Le meuble peut basculer et causer des blessures graves ou la mort.

Ancrer le meuble à une planche murale dans le mur (si indiqué).

Ne laissez pas les enfants grimper sur le meuble.

Placez les articles lourds sur les étagères ou dans les tiroirs inférieurs.

Astuces Utiles (page 2)

-Ouvrez votre article dans la zone que vous prévoyez de le garder pour moins de levage lourd

-Identifier, trier et compter les pièces avant d'essayer d'assembler

-Les goujons de compression sont taraudés avec un Marteau

-Les glissières sont marquées d'un R (droit) et d'un L (gauche) pour un bon placement

-Assurez-vous toujours de faire face la pointe situé sur le haut de la Serrure de Came vers le bord extérieur

-Utiliser tous les clous fournis pour le panneau arrière et les répartir également

-Le panneau arrière doit être utilisé pour vous assurer que votre appareil est robuste

-N'utilisez pas de produits chimiques agressifs ou de nettoyeurs abrasifs sur cet appareil

-Ne jamais pousser, tirer, ou faire glisser votre meuble

Avant de Commencer (page 3)

-Lisez attentivement chaque étape et suivez le bon ordre

-Séparez et comptez toutes vos pièces et matériaux

-Donnez-vous suffisamment de place pour l'assemblage

-Avoir les outils suivants: tournevis à tête plate, #2 tournevis Phillips, et Marteau

-Attention: Si vous utilisez une perceuse électrique ou un tournevis électrique pour visser, veillez à ralentir et arrêter lorsque la vis est bien serrée. Le non-respect de cette consigne peut endommager la vis.

Système de Fixation de Came (page 3)

Ce Système de Fixation de Came sera utilisé tout au long de l'assemblage

Page 9

Localisez le kit de glissière (21). Déployez la glissière comme indiqué et appuyez sur le levier de libération pour retirer la glissière intérieure. Mettez la glissière intérieure de côté pour plus tard. Commencez par fixer la glissière aux panneaux à l'arrière de la glissière. Tout en faisant glisser la glissière centrale, localisez les trous des panneaux avec le trou d'accès de la glissière centrale et fixez-les avec les vis (20) comme indiqué.

Levier de libération Glissière centrale Glissière extérieure Glissière intérieure Utilisez ces trous
Trou d'accès

Page 11

Ne serrez pas complètement la vis.

Page 14

IMPORTANT! LE PANNEAU ARRIÈRE EST UNE PARTIE STRUCTURE DE L'UNITÉ ET DOIT ÊTRE INSTALLÉ DE MANIÈRE ADÉQUATE.

Retournez soigneusement l'appareil sur sa face avant.

Positionnez le panneau arrière comme indiqué. Alignez d'équerre tous les bords et clouez droit dans les bords arrière comme indiqué.

Assurez-vous que l'unité est d'équerre.

La distance d'un coin à l'autre doit être égale, comme illustré.

Alignez le bord inférieur du panneau arrière avec le bord inférieur du panneau de base (D).

Page 19

Insérez le barillet de la serrure (12a) dans le trou comme indiqué. Serrez l'écrou de blocage (12c) en orientant les dents de l'écrou de blocage (12c) vers la surface de la porte. Positionnez la barre de verrouillage (12b) et fixez le barillet de la serrure (12a) avec la vis de verrouillage (12d). La barre de verrouillage (12b) doit être orientée vers la gauche. Lorsque vous tournez la serrure avec la clé, la barre de verrouillage tourne dans le sens inverse des aiguilles d'une montre et pointe vers le bas (position de déverrouillage).

Surface plate/lisse du barillet de la serrure.

Rainure de clavette verticale

Les dents de l'écrou de verrouillage se serrent contre la surface de la porte.

Page 20

Lors du montage de la porte gauche (F), assurez-vous que le boulon coulissant (17) est en position haute.

Lors du montage de la porte droite (G), assurez-vous que la barre de verrouillage (12b) est dirigée vers le bas.

Page 21

OPTION 1 : Fixation dans un montant de mur (méthode préférée)

À l'aide d'un détecteur de montants, localisez un montant dans le mur. Placez votre appareil contre le mur, avec le support de sécurité aligné à cet endroit. Pour faciliter l'insertion de la vis, vous pouvez percer un trou pilote de 3 mm de diamètre à travers le support de sécurité dans le montant. Enfoncez la vis à travers le support de sécurité dans le montant du mur. Serrez la vis qui n'a pas été entièrement serrée à l'étape 3.

OPTION 2 : Fixation dans les cloisons sèches

Placez votre unité à l'endroit souhaité contre un mur et marquez le mur à travers le support de sécurité, puis mettez votre unité de côté. Percez un trou de 3/16 de po de diamètre (5 mm) dans le panneau mural. Tapez sur l'ancrage mural dans le trou jusqu'à ce qu'il soit affleurant. Mettez votre appareil en place et fixez le support mural à l'ancrage mural à l'aide de la vis. Serrez la vis qui n'a pas été entièrement serrée à l'étape 3.

Page 30

Installez le tiroir en insérant la glissière intérieure dans le rail de la glissière centrale et en l'enfonçant complètement.

Page 31

Pour verrouiller votre armoire :

Fermez la porte gauche (F), appuyez sur le pêne coulissant (17) dans le trou du fond (D). Fermez la porte de droite (G) et tournez le verrou (12) pour que la barre de verrouillage tourne vers la gauche et derrière la porte de gauche (F).

Page 32

Pour ajuster la hauteur verticale :

Desserrez les vis "A" sur les deux charnières. Ils sont généralement dans des trous à fentes qui vous permet de s'ajuster vers le haut ou le bas de quelques mm. Puis resserrez-vous.

Pour ajuster la profondeur :

Desserrez la vis "B" et ajustez la porte.

Pour s'adapter d'un côté à l'autre :

Desserrez la vis "C" sur les DEUX charnières et serrez "B" ajuste la porte vers l'extérieur. Desserrez "B" et serrez "C" ajuste les portes vers l'intérieur.

Page 33

CHARGES MAXIMALES

Ce meuble a été conçu pour supporter les charges maximales indiquées. En excédant ces limites de charge, le meuble pourrait devenir instable, s'effondrer, et/ou causer des blessures graves.

AVERTISSEMENT : Risque de blessure corporelle - ne pas placer une télévision sur ce meuble. Ce meuble n'est pas approuvé pour une utilisation avec une télévision.

Page 34

Enregistrez votre produit pour recevoir les éléments suivantes:

- * Détails sur les nouvelles tendances - un aperçu sur les nouveautés
- * Sondages - avoir une voix au sein de notre communauté
- * Offres exclusives et codes promo
- * Service de pièces de rechange rapide et facile

Pour enregistrer votre produit, visitez ameriwoodhome.com

5 Étoiles

Visitez le site Web de votre détaillant local, évaluez votre produit acheté et laissez-nous quelques commentaires !

Nous tenons à offrir un grand "Merci" à tous nos clients pour avoir pris le temps d'assembler ce produit "Ameriwood Home", et de nous donner vos commentaires précieux.

Merci